

DTG Printer

catalogue

Ready firstly	- 2 -
1.1 Safety matters	- 2 -
1.2 System requirements	错误! 未定义书签。
Chapter 2 Understanding the equipment	- 5 -
2.2 Appearance and understanding of the machine	- 6 -
.....	- 6 -
Chapter 3: Software Installation	- 7 -
Chapter 4 Start up and go online	- 8 -
4.1. Start-up	- 8 -
(1) Check whether the waste ink pipe is correctly put into the waste ink cartridge before starting up	- 8 -
(2) Whether the fixing bracket of the ink car is removed, and manually move the ink car left to check the height of the ink car and the platform	- 8 -
(3) Plug in the power cord to power on the machine.(Effective earth wire is required)	- 8 -
(4) Use the touch screen to control Y1 and Y2 forward and backward, and test for normal operation.	- 8 -
4.2. Online	- 8 -
Chapter 5: Movement Settings	- 12 -
5.1 Z-axis alignment	- 12 -
第六章 Spray head installation	- 19 -
第七章 calibration	- 23 -
7.1 Head test	- 23 -
Note; move the Y1 platform using the touch screen to the last connected online (and use the film, hot film, silver light paper and other transparent materials on the Y1 platform to observe the status of white ink and colored ink)	- 23 -
Chapter 8: Software Introduction	- 30 -
No.27 icon function nozzle selection; 2HC (8C) _ 2 HW _ M	- 34 -
Version 8.4.1 information	- 40 -
8.4.2 Broken hole compensation	- 40 -
8.5 Log	- 41 -
Click the log button in the lower right corner of the printing software to enter the log window, as shown in the figure below:-	41 -
Chapter 10 Daily Maintenance	- 46 -
.110 Machine maintenance	- 46 -
10.2 nozzle maintenance	- 47 -
.1 11 Error printing	- 49 -
.211 Clean the nozzle out of the waste ink	- 49 -
.3 11 A replay appears when printing the picture	- 49 -
.4 11 Picture printed with pull	- 49 -
.5 11 There is a broken square ink when printing the pattern	- 50 -
11.6 Misalignment when printing patterns	- 50 -
11.7 The nozzle does not give ink	- 50 -
11.8, startup failure	- 51 -
11.9 Print accuracy problem	- 51 -

Chapter 1-Ready firstly

1.1 Safety matters

- ◆ (1) . You should check the voltage of your country firstly. If the voltage on your side is not stable or is too high, it is recommended that you buy a voltage stabilizer or an UPS(Uninterrupted power supply) to protect the printer and yourself. You can read the "Computer configuration and circuit wiring requirements" that we sent.
- ◆ (2) . Place the TDG on a horizontal and stable position. If the equipment is tilted, the machine may not work properly. Leave enough space around the equipment to ensure proper ventilation of the equipment.
- ◆ (3) . Place the device near the wall socket to plug the plug easily.
- ◆ (4) . Avoid using equipment where temperature and humidity are prone to dramatic changes. Avoid printer exposure Direct radiation to sunlight, strong light, or heat source.
- ◆ (5) . Machine's better working temperature is 15-28 ° C; humidity: 60% -80%. To make the machine accessible. In order to make the machine run in the best condition, please configure the air conditioner and hygrometer indoors.
- ◆ (6) . Please compromise the use / storage of this product to avoid improper use / storage (such as rodent, liquid Body infiltration, etc.) to

cause failure, damage.

- ◆ (7) . Do not block, cover the opening on this product case.
- ◆ (8) . Do not insert any items into the print slot. Be careful not to splash the liquid onto the product.
- ◆ (9) . All equipment shall be connected to a properly grounded power plug. Avoid working with the copier or empty

Adjustment system these frequently switched equipment use the socket in the same circuit.

- ◆ (10) . Keep your entire computer system away from potential electromagnetic field interference, such as speakers or
The base for the wireless telephone.

- ◆ (11) . Only the type of power indicated on the product label.

- ◆ (12) . Do not use damaged or cracked power cords.

- ◆ (13) . If this product uses additional power cables, ensure that the total amps of the additional power cord device inserted does not exceed the rated amps of the power cord. Also, ensure that the total amp of all equipment inserted in the socket does not exceed the rated amp of the wall socket.

- ◆ (14) . The machine must be kept away from strongly interfering radiation sources.

- ◆ (15) . Always use the power switch to turn off the device. Do not unplug the device power plug or other related data cables until the machine power is disconnected.

- ◆ (16) . Please do not put tools or other items on the printing platform or cover plate of the machine, so as to avoid unnecessary losses caused by improper cleaning before the machine runs.
- ◆ (17) . Before handling the equipment, make sure your print cart is fixed in the primary position.
- ◆ (18) . The grating bars should be checked frequently for any damage
- ◆ (19) . Do not let the nozzle leave the ink station for a long time
- ◆ (20) . Under the abnormal shutdown state, do not pull the ink car by hand, should be turned on to automatically reset
- ◆ (21) . Please place the ink bottle out of the child's reach
- ◆ (22) . If the ink sticks to the skin, wash with soapy water. If the ink splashes into the eyes, rinse with water
- ◆ (23) . After the ink bottle is used for a period of time (generally three months), it should be thoroughly cleaned once and dry before it can be reused
- ◆ (24) . Place the ink in a cool place to avoid direct sunlight

Chapter 2 Understanding the equipment

2.1 Product parameters

Machine size	length	1628mm
	width	2200mm
	altitude	1281mm (excluding alarm)
Applicable fabric	type	Cotton, hemp, knitting and other cotton content of more than 30%
Inkjet ink	type	Textile paint ink, white ink
	pigment	K、C、M、Y、R、G、W
Print wide	The 380-mmX500mm duplex position 880mmX500mm single-work site	
Print the nozzle	5113 / 4720 Double head and four head	
Printing parameters	accuracy	360~3600DPI
	velocity	m ² /h
Power supply parameters	rated voltage	200V~240V
	frequency	50~60HZ
	rated current	5A
Power parameters	printing equipment	300W
service environment	temperature	15~28 Degrees
	humidity	60~80%

2.2 Appearance and understanding of the machine

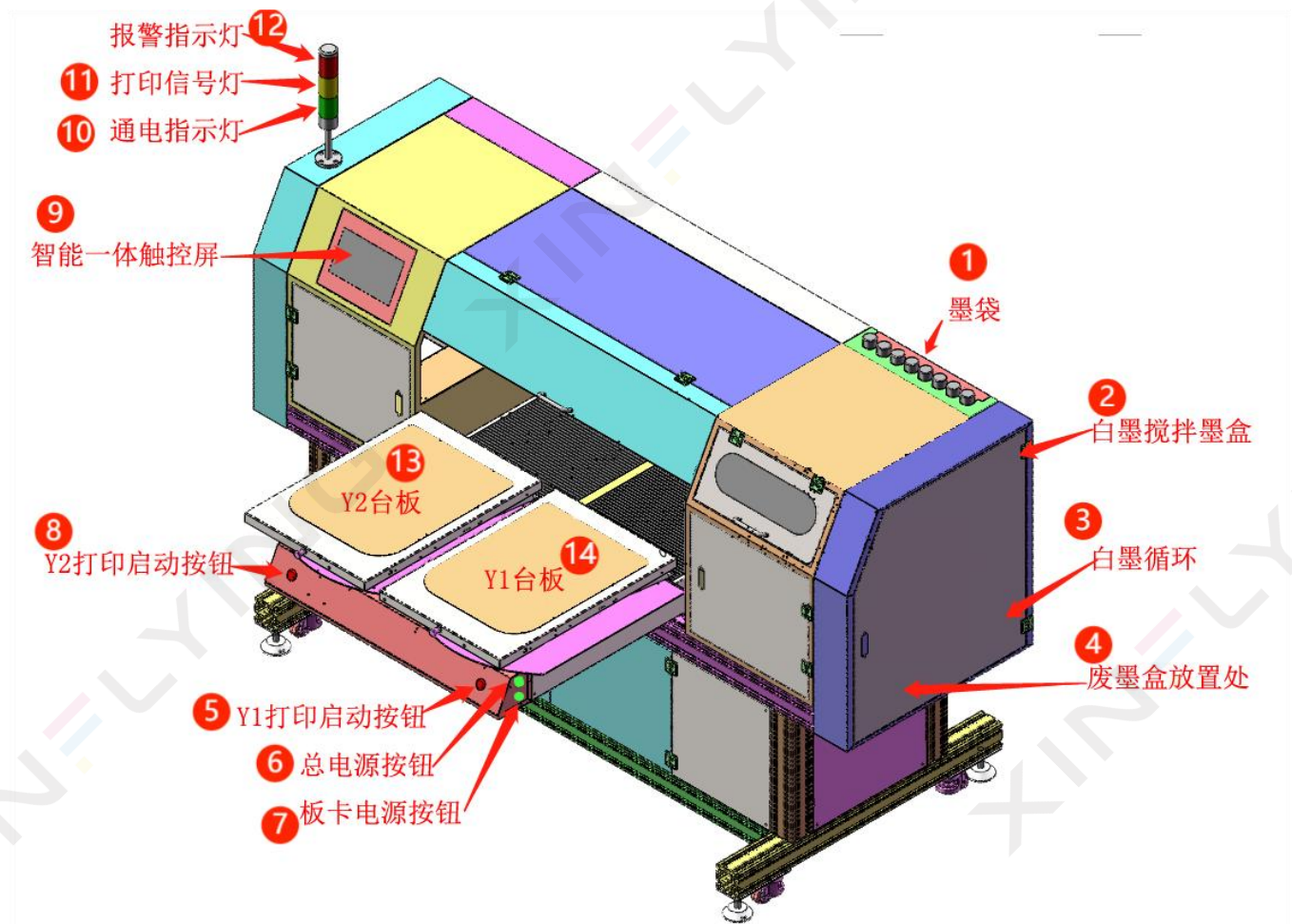

NO.	Name	NO.	Name
1	Ink cartridge	8	Y2 Printing
2	White ink mixing cartridge	9	Smart touch panel
3	White ink circulation system	10	Power indicator light
4	Waste ink tank placing position	11	Printing single indicator light
5	Y1 printing boot button	12	Alarming indicator light
6	Main power supply button	13	Y2 Clothes Placing Table
7	Board power supply button	14	Y1 Clothes Placing Table

Chapter 3: Software Installation

(1) Place the compression package in any disk outside of the system disk, and then unzip it

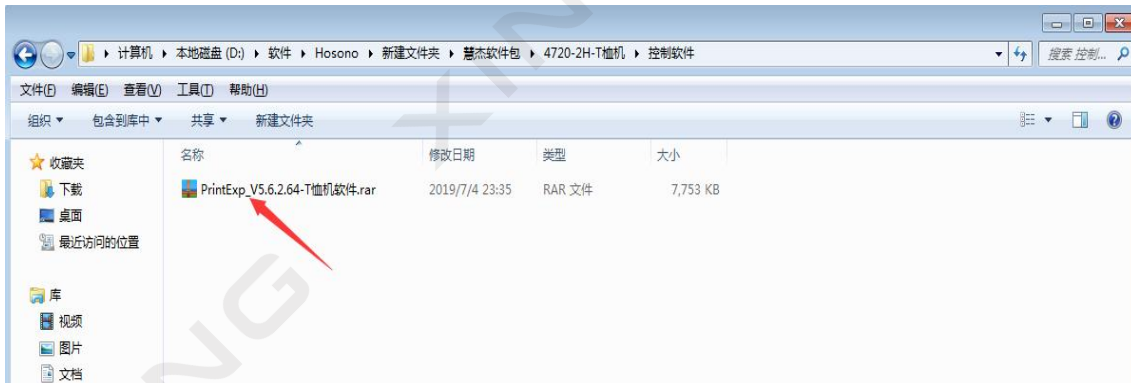

(2) Open the extracted folder

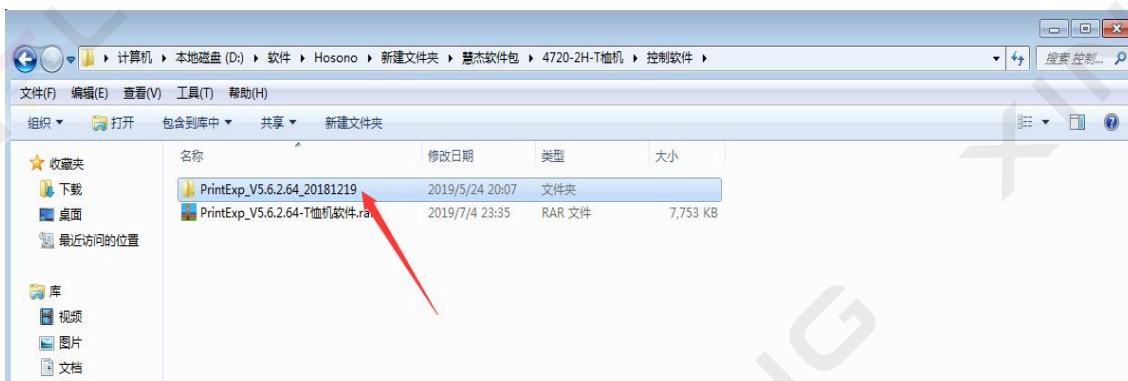

(3) Pull down the mouse, find the icon indicated by the red arrow in the picture, and right click to the desktop shortcut

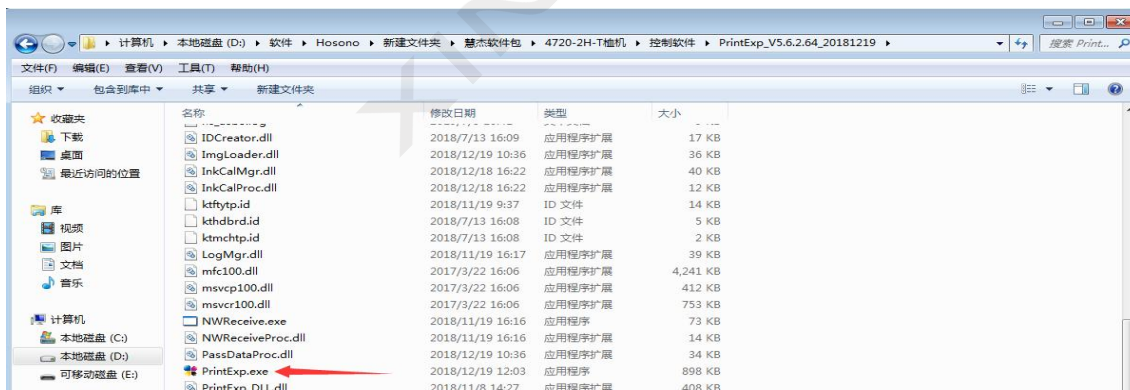

Chapter 4 Start up and go online

4.1. Start-up

- (1) Check whether the waste ink pipe is correctly put into the waste ink cartridge before starting up
- (2) Whether the fixing bracket of the ink car is removed, and manually move the ink car left to check the height of the ink car and the platform
- (3) Plug in the power cord to power on the machine. (Effective earth wire is required)
- (4) Use the touch screen to control Y1 and Y2 forward and backward, and test for normal operation.
- (5) The TCP / IP network cable of the machine is plugged into the computer.
- (6) Find the following icon on the computer desktop and double-click to open the software.



4.2. Set the online IP address of the printing software

Before connecting to the network, check that the computer has a gigabit network card in order to connect normally. The difference between a gigabit network card and a 100Mbps network card: Gigabit network cards contain these characters: Gigabit, GBE, 10/100/1000M, RTL8169.

100Mbps network card contains the following characters: Fast Ethernet, 10/100, FE.

Enter the computer's device manager to check the network adapter.

The control software version must match the board version, and after completing the installation according to the instructions in the installation package for both the control software and RIP software, IP settings can be configured for networking. Open the software → Advanced settings → Communication settings → TCP communication → Enter the local host IP: 192.168.127.11 → Control Panel → Network and Internet → Network connections → Right-click on 'Properties' → TCP/IPv4 → Click on 'Properties' → Check 'Use the following IP address' and modify the IP address to 192.168.127.11.

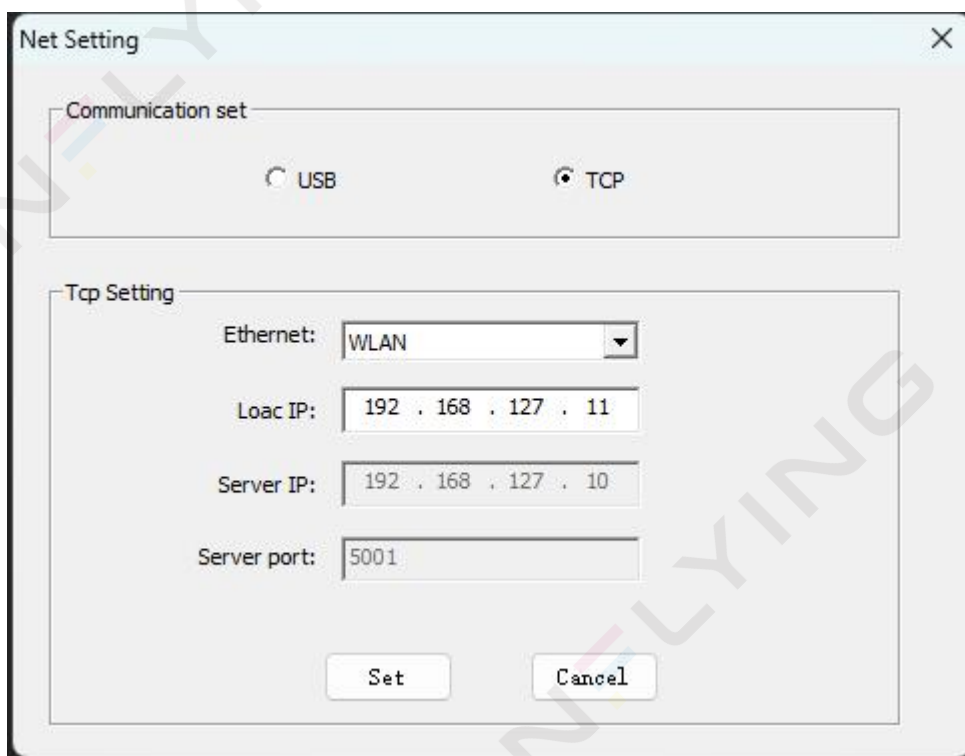

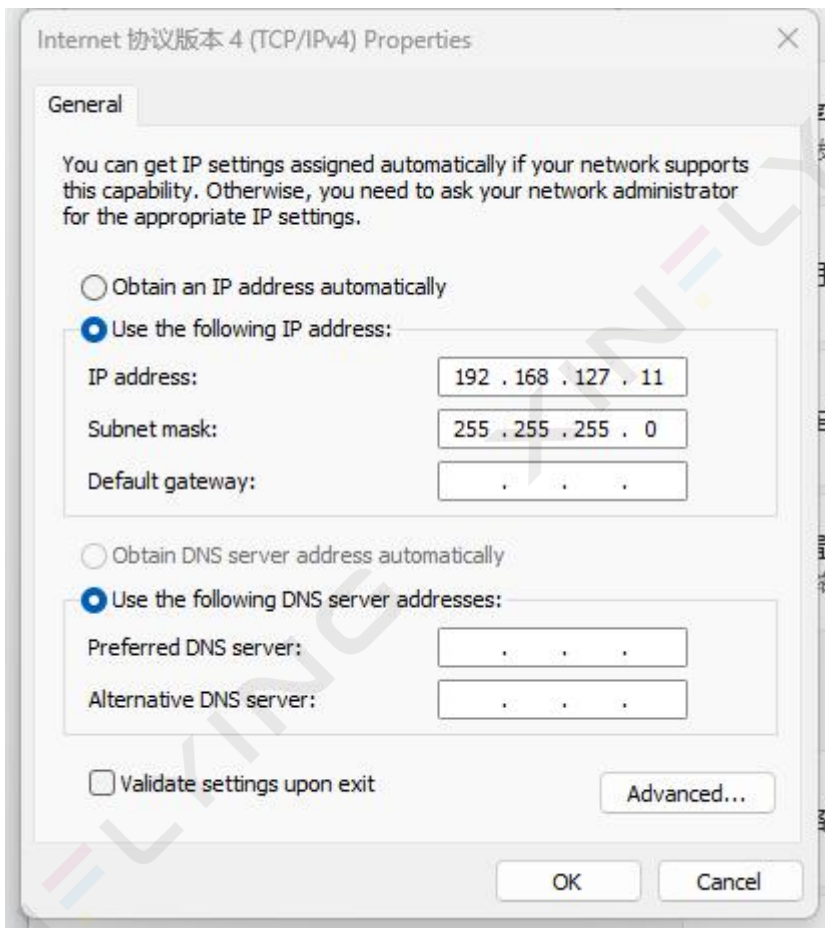

After setting up, please click the upper right corner of the software, click save parameters, and then return to the main interface window. You can see that the first icon in the lower left corner of the main interface is green indicating that the machine is connected. If it is still red and the machine is not connected, you can unplug the network cable and try again to see whether the machine is connected. If the machine is still impossible, check whether the network cable is good.

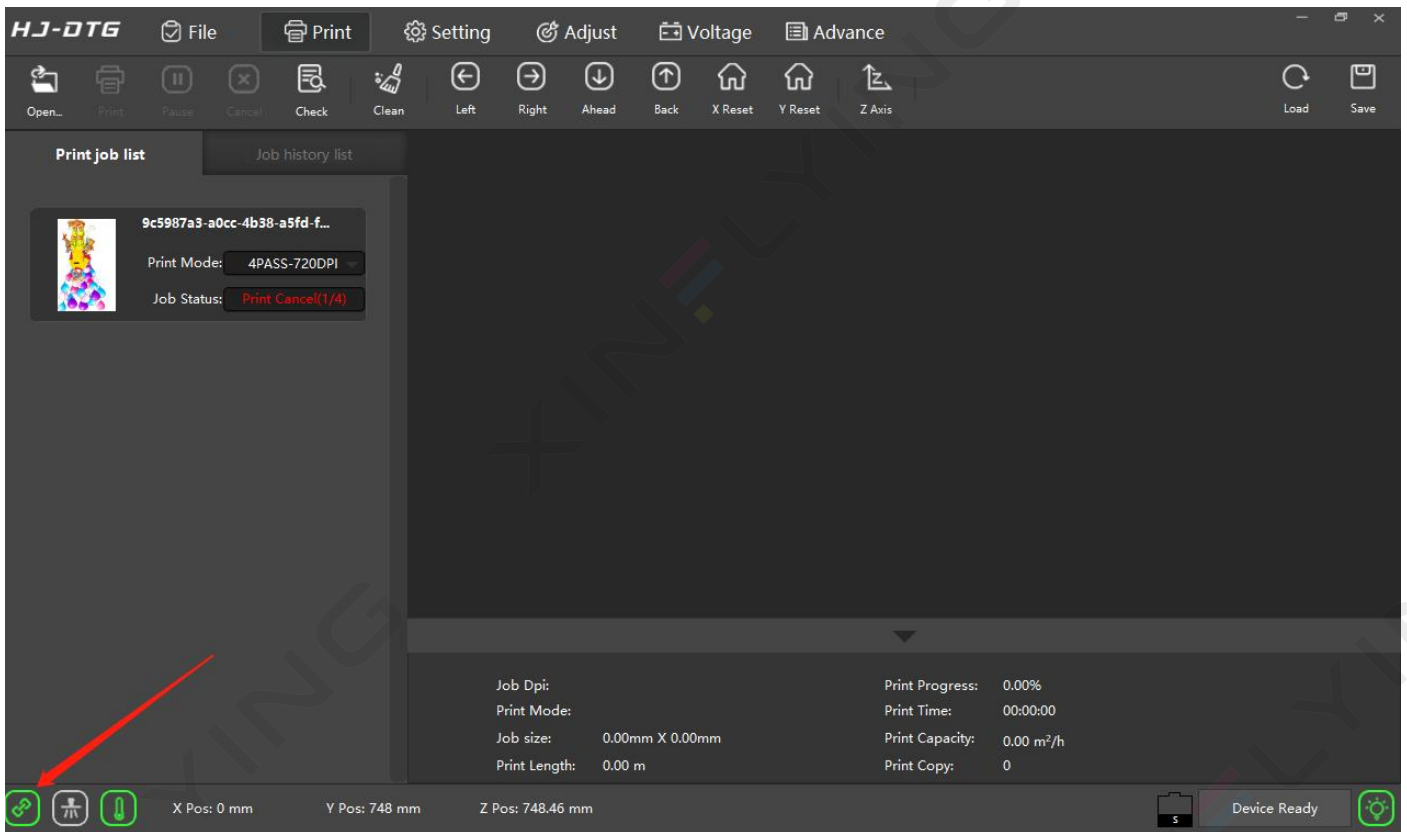

Interface Introduction:

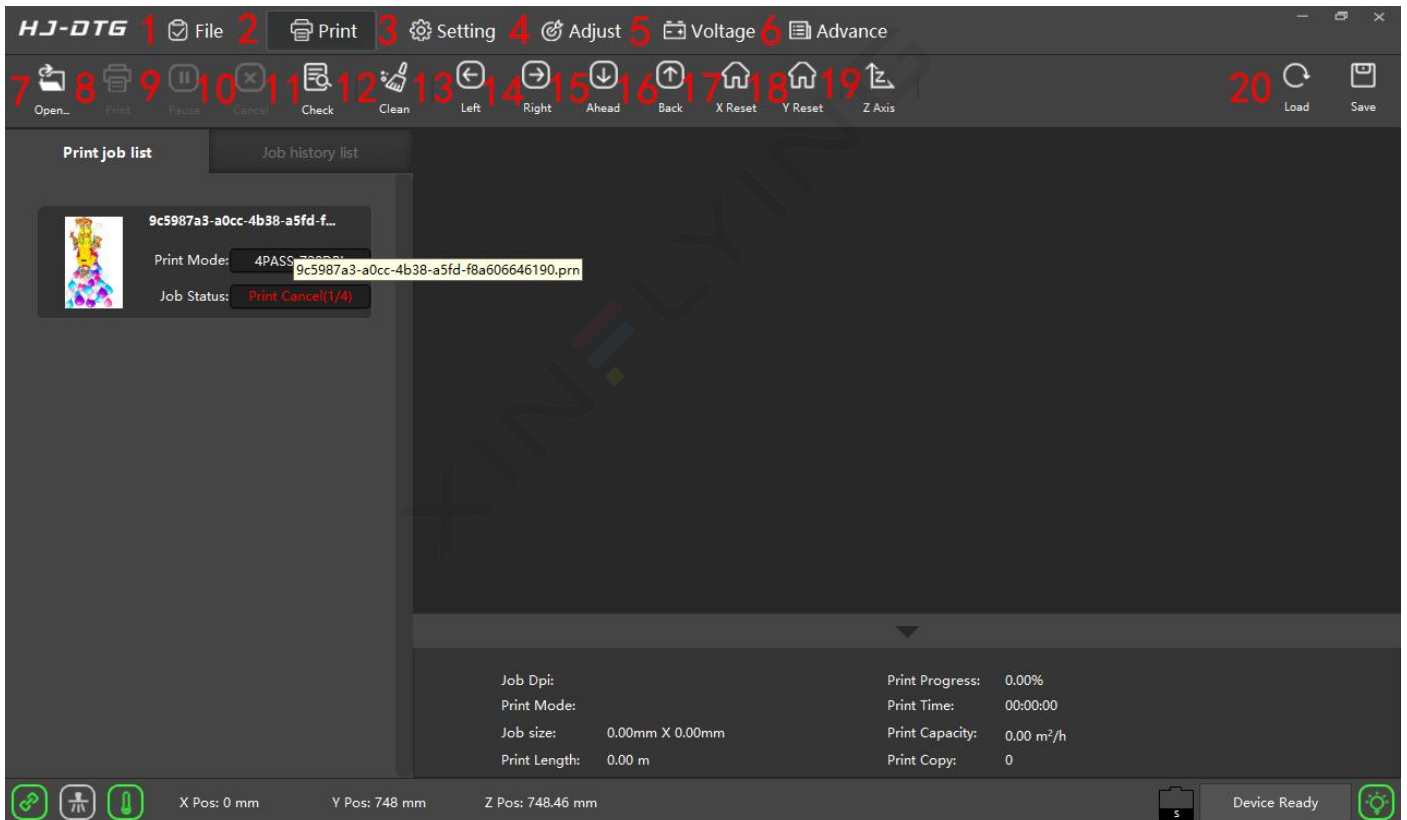

NO.	Name	NO.	Name
1	Open file	11	Print nozzle test, check the ink came out in a good condition
2	Print	12	Clean the print head, always choose "weak clean"
3	Setting, basic function	13	Carriage move to the left
4	Adjust(Print head calibration)	14	Carriage move to the right
5	Voltage (the voltage of print head, Please do not make unauthorized changes. Our company is not responsible for unauthorized changes)	15	Printing film move forward
6	Advance(can be check the main board information)	16	Printing film move backward
7	Open the files	17	X Reset : Carriage Reset
8	Being printing the selected task	18	Y Reset: Printing platform Reset
9	Start and Stop printing	19	Z Axis: Carriage lift up and down
10	Cancel the printing or waiting to print task	20	Load parameters; Refers to loading parameters in the board Save parameters; To change any parameter on the software interface, you must click Save parameter, otherwise the parameter change is invalid

Chapter 5: Movement Settings

5.1 Z-axis alignment

Note; Click left to separate the ink car from the ink stack, measure the actual spacing with the ink stack floor and record it

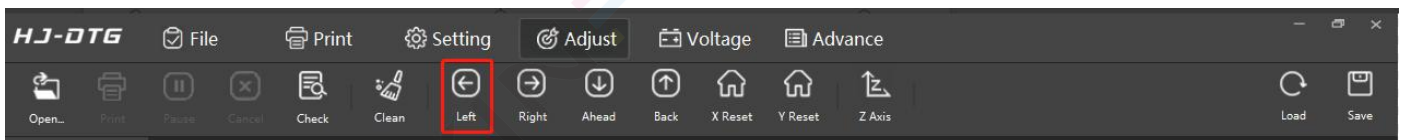

According to the instructions below, enter the advanced interface and enter the calibration interface

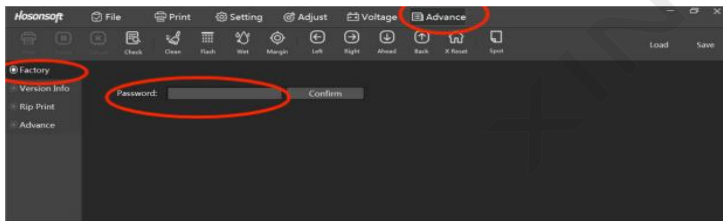

- (1) Choose Z motor
- (2) Enter the value 5 in the input box to the right of the target move value
- (3) Click on the mobile
- (4) After waiting for the ink car to stop lifting, measure the actual spacing between the ink stack floor and the ink car bottom (use the actual value recorded minus the actual value after moving) and input the value into the input box on the right of the actual moving value
- (5) Click calculation (calculation can only click once, can not repeat click)
- (6) Re-record the distance between the ink car floor and the ink stack floor, and repeat steps 2 and 3, and measure the actual value after moving (using the recorded value minus the moving value) to confirm whether it is the input target movement value

After the calibration is complete, click the upper left corner file to save

5.2 The X-axis calibration

Note; click Z axis, input value 17 in the input box, click Position height, and click Save

Exit

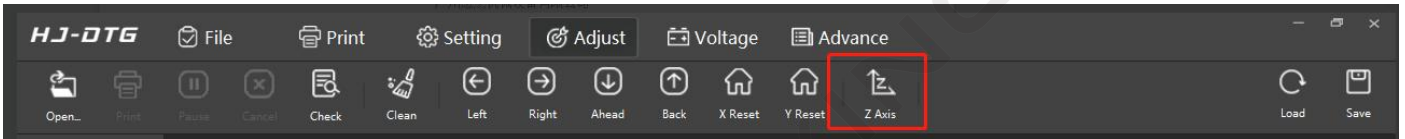

(1) Enter the advanced interface according to the instructions below, and enter the calibration interface

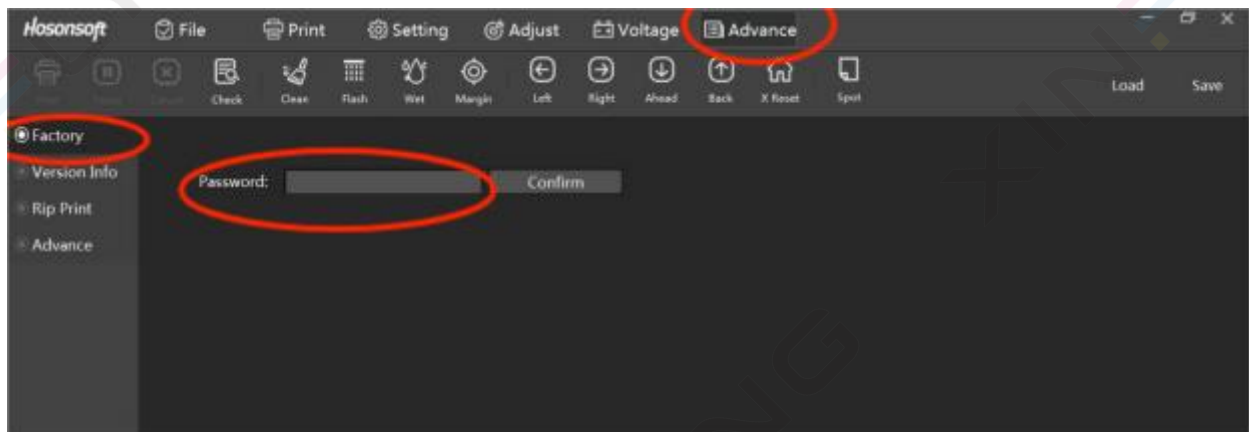

(2), set the target movement value to 100 as shown in the figure below, and then click Calibrate.



Wait for the ink car to stop moving. After automatic reset, enter the target move value of 1000 again, click calibration, and wait for the ink car to stop moving. After automatic reset, click the file in the upper left corner to save

5.3. Y-axis calibration

Note: Select the dual Y mode at the touch screen and return the platform to the inside and go online

1. The Y1 platform is calibrated according to the location indicated in the figure below



- (1) Choose Y motor
- (2) Select motor Y (motor Y=Y1 platform, motor 2=Y2 platform)
- (3) Enter the target movement value (column; 500 mm)
- (4) Click Move (mark to measure the actual distance after the move)
- (5) Enter the actual measurement data
- (6) Click calculation (only once, repeat 3 and 4 steps to measure the actual

distance)

(7) Repeat Step 2 to select motor 2 (repeat 3,4,5,6, steps) for Y2 platform calibration

After the calibration is complete, click the upper left corner file to save

5.4 Head cleaning action setting (following settings only fine tuning)



5.4.1. The height setting of the scraper motor

(1) Click the scraper, select the nozzle 1, input the value in the right input box of the position of the scraper to set the scraping height of the scraper motor (front watch the scraper, vertical, the value in thousands) click the file in the upper left corner to save

5.4.2. Set the height of cleaning and pumping ink

(1) Select the nozzle 2, enter the value in the input box on the right side of the scraper position to set the height of cleaning ink extraction (all the nozzle can be separated from the ink absorption pad by 2 mm, and the value can be added or reduced in thousands). Click the file in the upper left corner to save

5.4.3. Head ink-scraping height setting

(1) Select the nozzle 3, enter the value in the right input box of the side of the scraper position to set the height of the nozzle (the scraper is slightly across the surface of the nozzle, and the value in thousands). Click the file in the upper left corner to save

5.4.4. Flash flash height of nozzle

(1) Select the nozzle 4, input the value in the right input box of the scraper position to set the nozzle flash injection height (all the nozzle can be separated from the ink absorption pad by 2 mm, and the value can be added or reduced by thousands). Click the file in the upper left corner to save

After the fine tuning, observe whether the action of the above ink car is normal

5.5 The nozzle moisturizing height is set

(1) Click Clean, enter the value in the input box on the right side of the moisturizing Z target, (click the file in the upper left corner to save, and click X reset) to see whether the nozzle and the ink absorption pad fit (if not fit, add the value, and reduce the value too much)

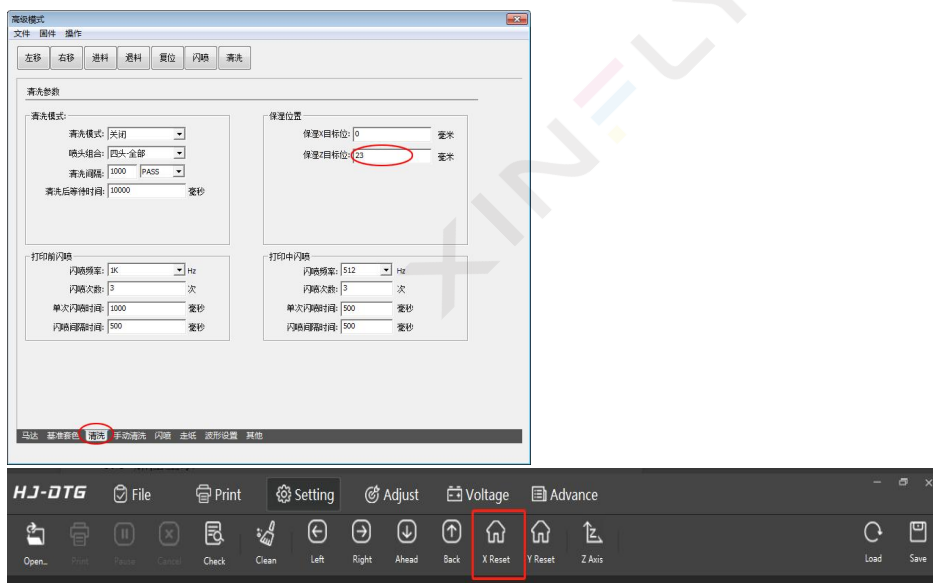

5.6 Set the nozzle print height

(1) Move platform Y to the middle, click left to move the Y above platform

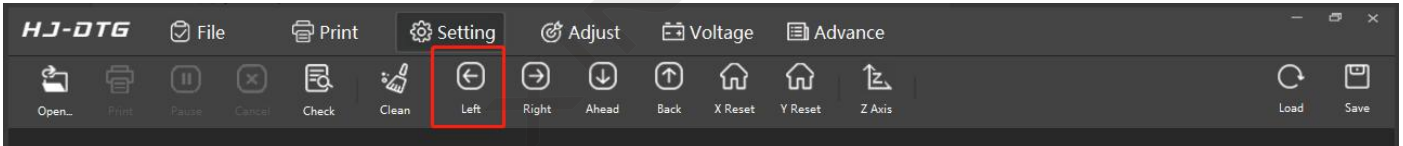

(2) Click on the Z axis

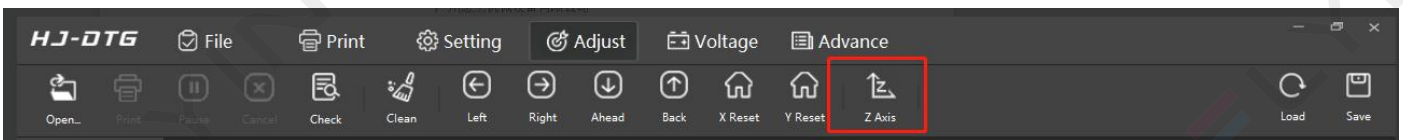

(3) According to the actual situation, click up or down, adjust to the height spacing between the nozzle surface and the Y platform of 3 mm (two one-yuan coin thickness, the nozzle surface can not contact any object)



(4) Check the actual value displayed in the Z position in the lower left corner, input the value into the input box below the media positioning and click the location height, and click Save to exit.



Chapter 6: Spray head installation

6.1 Installation of the nozzle and the nozzle row lines

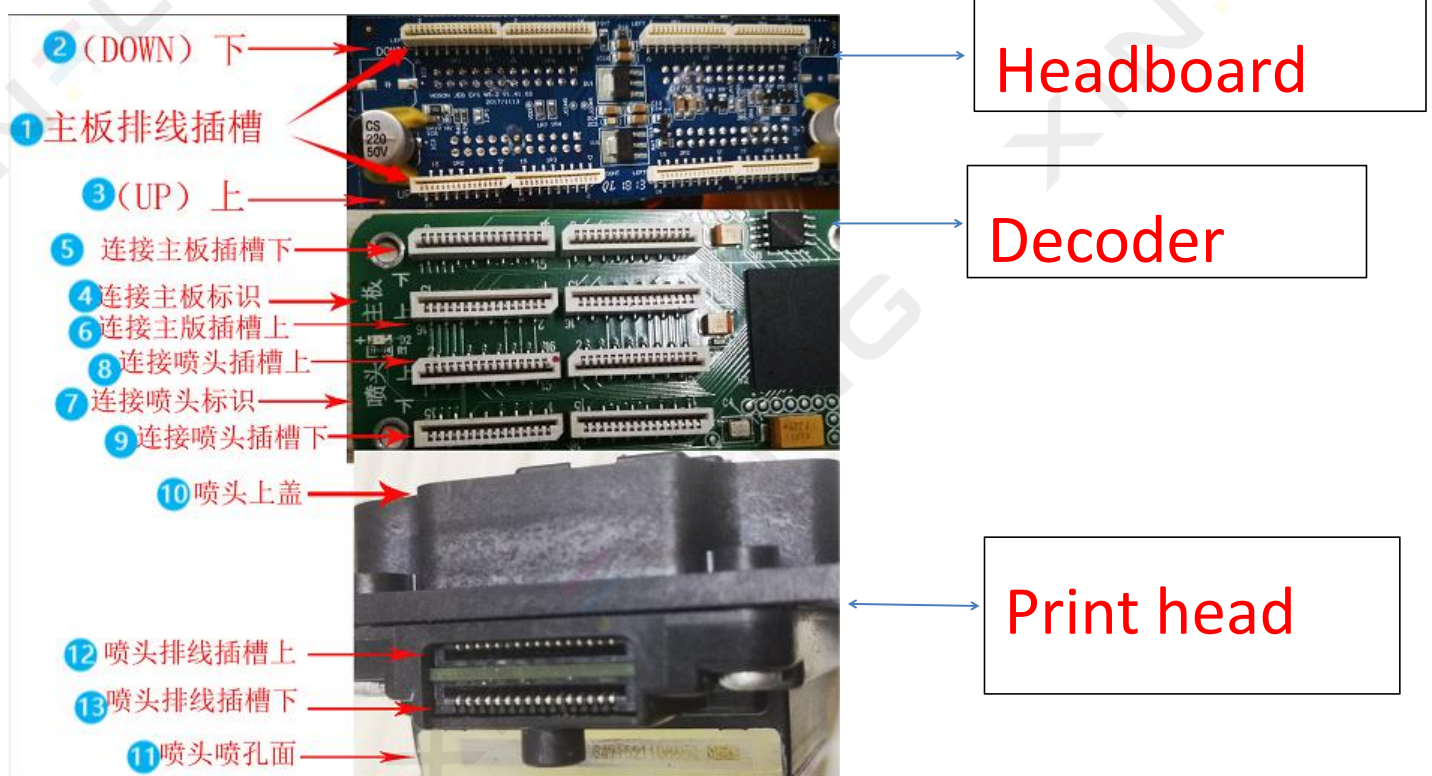

NO.	Name	NO.	Name
1	Head board cables port	8	Connect to the print head (Up)
2	Head board cables port (Down)	9	Connect to the print head (Down)
3	Head board cables port (UP)	10	The cover of Print head

4	Decoder	11	Print head' s surface
5	Mother board cable slot (Down)	12	The Position of Print head cable connection (Up)
6	Mother board cable slot (Up)	13	The Position of Print head cable connection (Down)
7	Connect the print head' s cables mark		

Please operate according to the instructions above (motherboard cable slot "DOWN" connection transfer card "motherboard slot" motherboard left cable slot connecting the left slot of the switch card, the right is the same) if you have any questions, please consult our company, do not install yourself.)

6.2 Installation of the print head

(1) Operation and install the print head according to the following figure, (please contact the company if you have any questions)

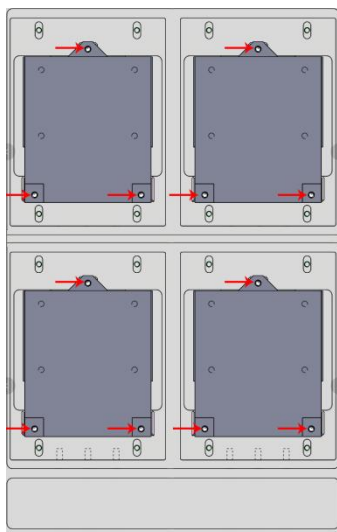

The arrow above points to the screw hole to fix the print head. Please fix the print head according to the figure above

(2) 5113 print head installation transfer interface (4720 print head directly uses ink damper)

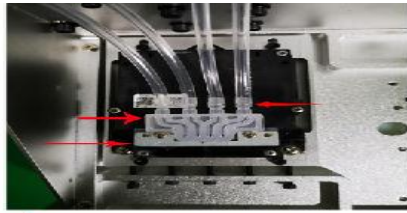

一；将图中箭头所指处两颗螺丝拆掉



二；配件：螺丝两颗，转接头一个，密封圈一个，压片一个



四；将带有密封圈的转接头放入墨水入孔内，将压片放在转接头上，并用螺丝固定好，将墨管插入转接头处

三；将密封圈套入转接头



- 一. Unscrew the two screws as the arrow shows
- 二. Accessories shows like the picture shows
- 三. Place the sealing rings in the adapter
- 四. Put the adapter with sealing ring into the ink hole, place the pressing clip on the adapter head, secure it with screws, and insert the ink tube into the adapter head

After the interface installation is completed, insert the ink pipe into the interface. If you have any questions, please consult our company. Do not install it by yourself

6.3 Fill the ink

- (1) Add ink according to the color label of the ink cartridge, and add two-thirds of the ink bag
- (2) Click Settings, select four heads-all, click loading ink, stop loading ink after 30

seconds, and clean the spray head after loading ink

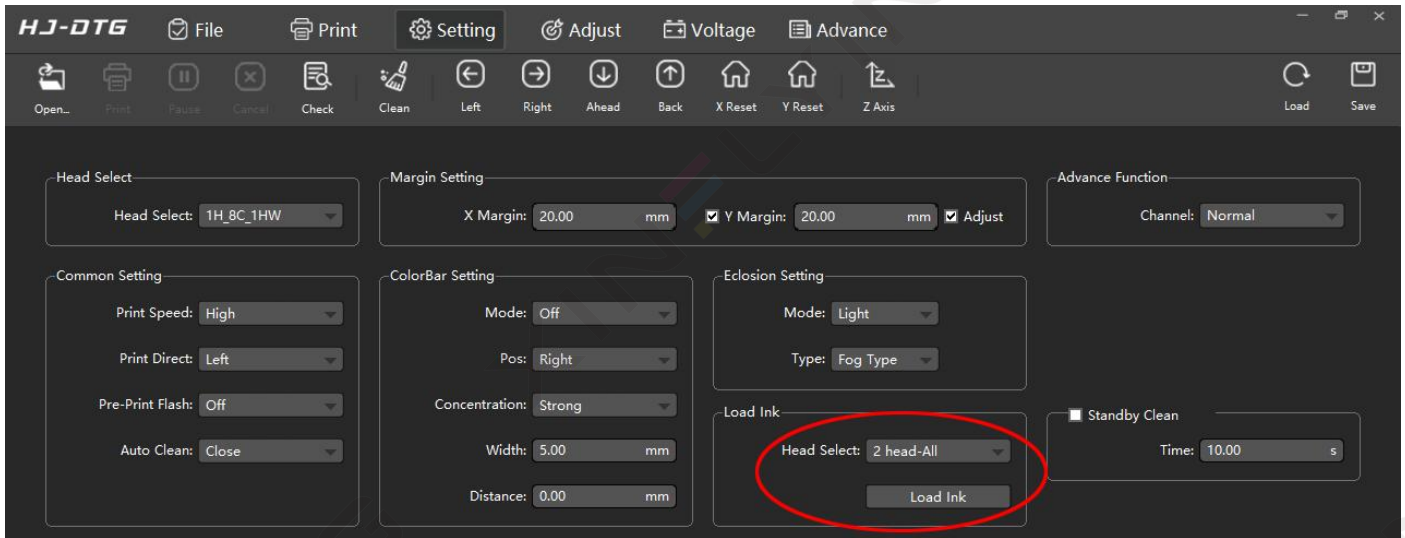

The ink can enter the nozzle through the damper (the same as the stop icon). If the ink cannot enter the ink pipe normally, it is necessary to check whether the damper is damaged and leaks, whether the ink absorption pad is completely close to the nozzle height, whether the ink absorption pad and the nozzle are offset, and whether the ink extraction motor is operating normally)

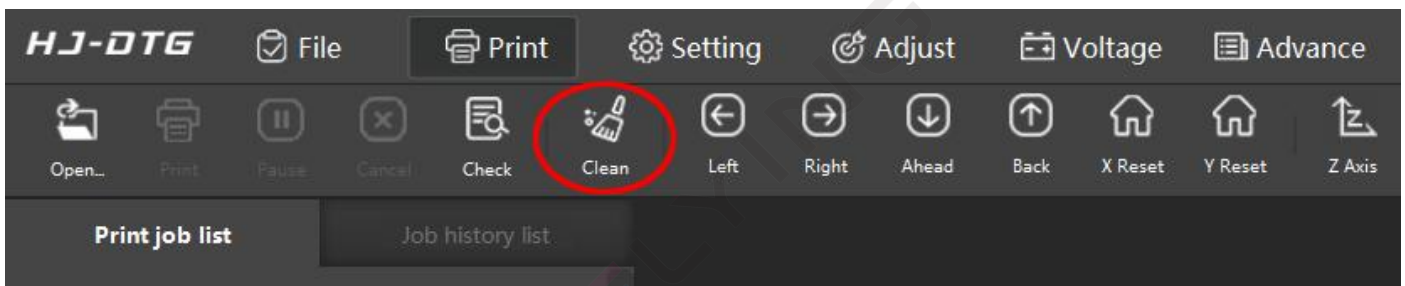

Click clean to select; four head-all (clean all nozzle)

Four-H0 (cleaning nozzle 1)

Four-H1 (cleaning nozzle 2)

Four-H2 (cleaning nozzle 3)

Four-H3 (cleaning nozzle 4)

Chapter 6: Calibration

7.1 Head test

Note; move the Y1 platform using the touch screen to the last connected online (and use the film, hot film, silver light paper and other transparent materials on the Y1 platform to observe the status of white ink and colored ink)

(1) Print head test

Click Calibration Select select Head Test

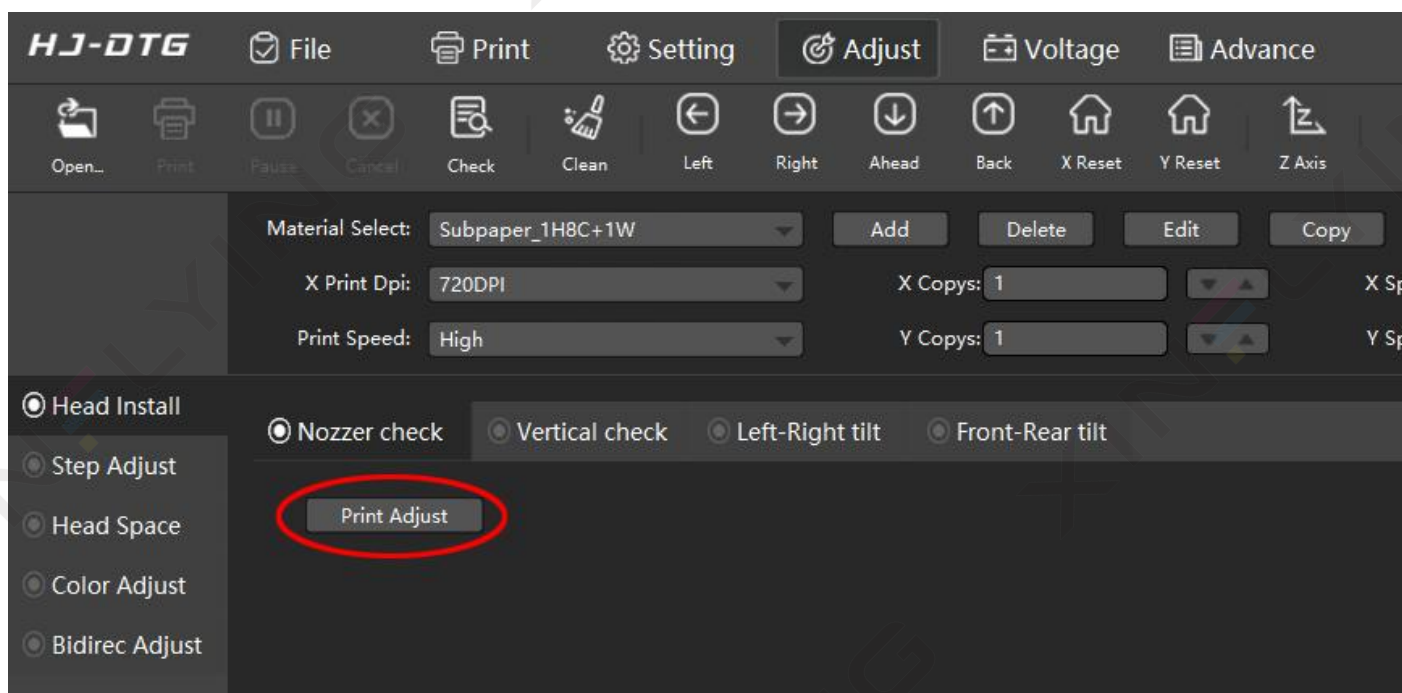

There are many breaks in the red circle below, please click clean



The following figure shows the complete figure of the test line

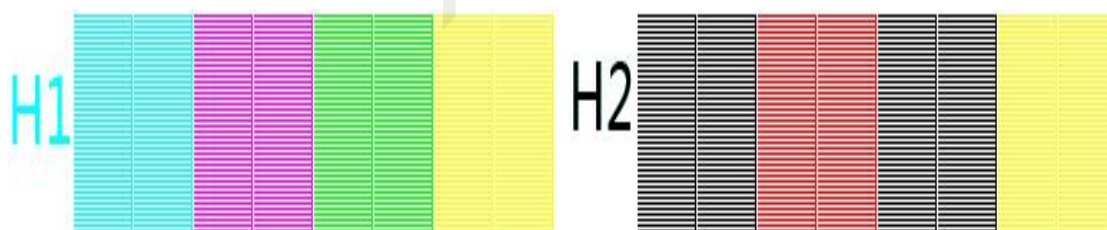

7.2 Vertical calibration

(1) Select the nozzle test, click the vertical test to print (the platform board does not need to return to the inside, directly online)

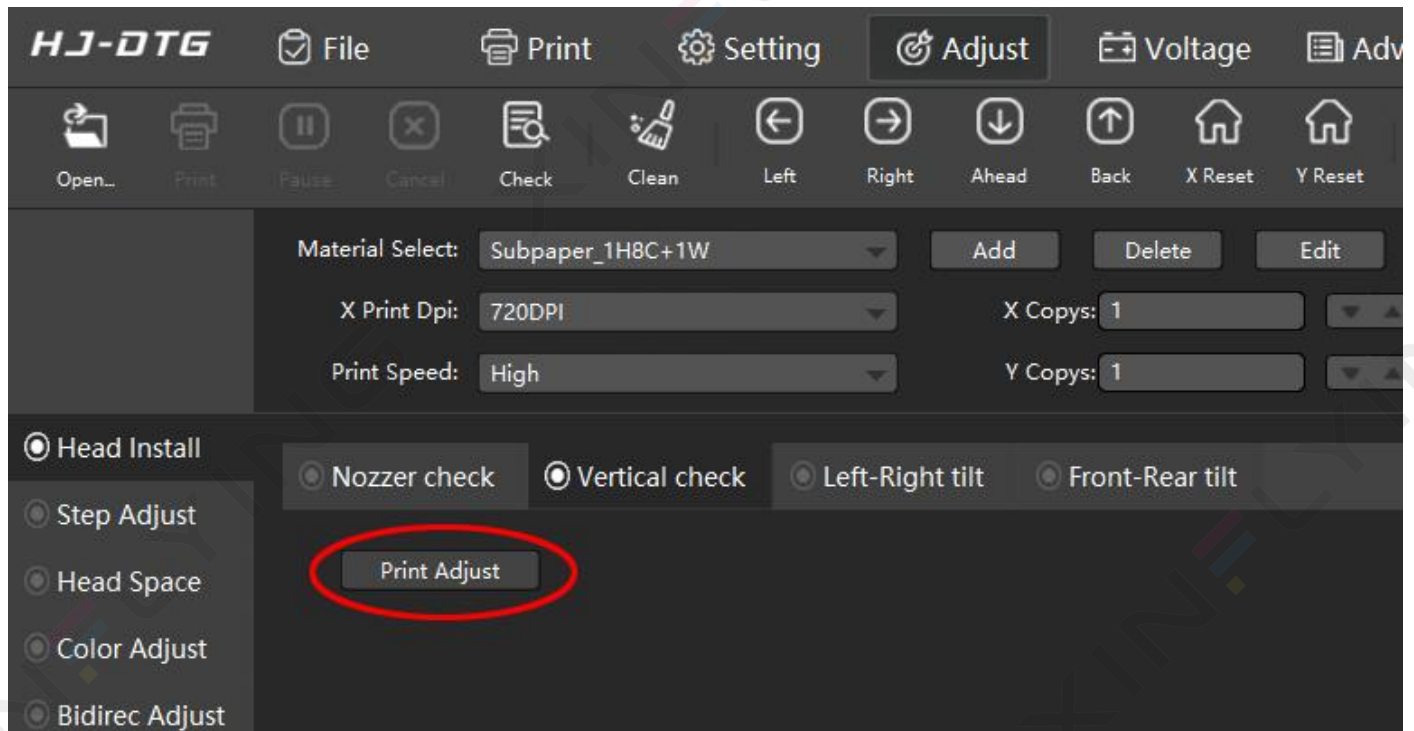

(2) The offset at the red circle occurs, that is, the vertical is not well calibrated and needs to be calibrated

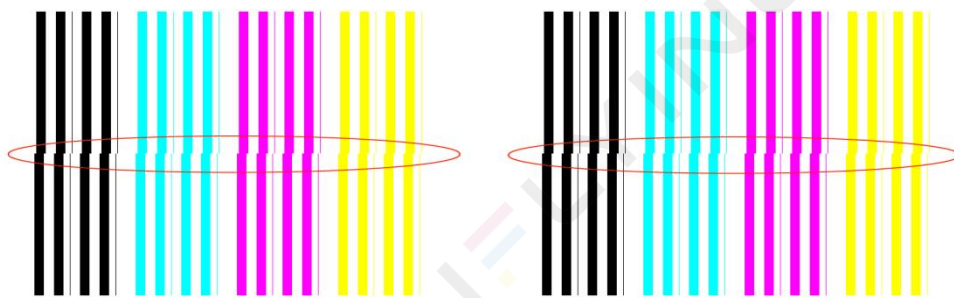

(3) Release the four screws pointed out by the orange arrow (not removed)

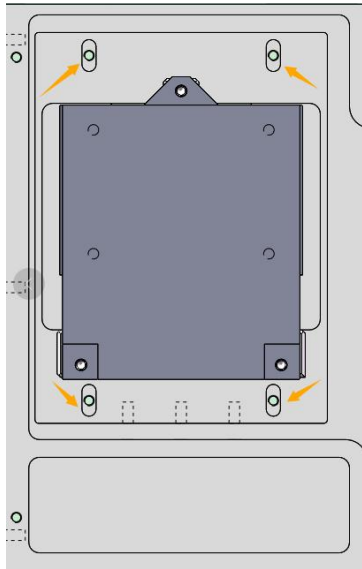

The four colors on the left are offset, that is, loosen the five screws on the left nozzle

(4) There are five arrows marked in the figure, the middle three arrows are the outward nozzle, the left and right sides are the inner nozzle,

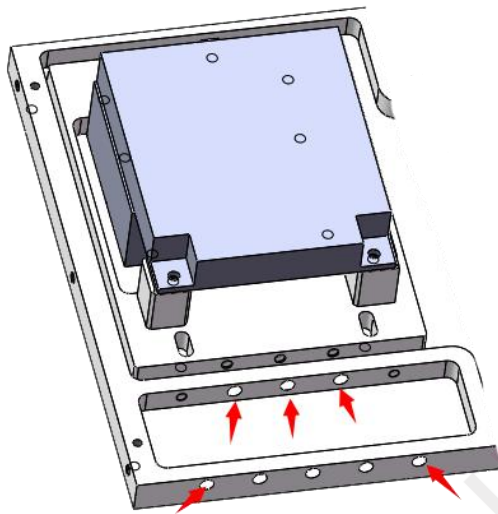

(4) The offset of the vertical calibration is the same as the figure, that is, loosen the screw shown by the first arrow, pull the screw shown by the second arrow (the screw can rotate half a circle), then tighten the screw shown by the previous orange arrow, and print the vertical calibration diagram.(The above operation is a complete operation. If the printing vertical calibration is not standard, please continue to

repeat the above operation.)

The following figure shows the vertical calibration diagram for the standard demonstration

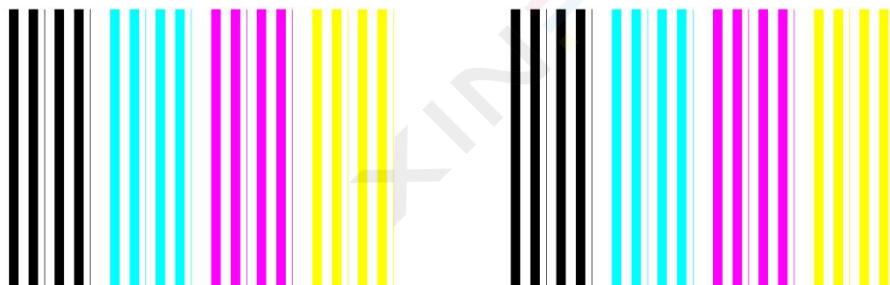

7.3 Horizontal spacing calibration (the platform plate does not need to return to the bottom, directly online)

(1) Select the nozzle spacing and click the left calibration to print

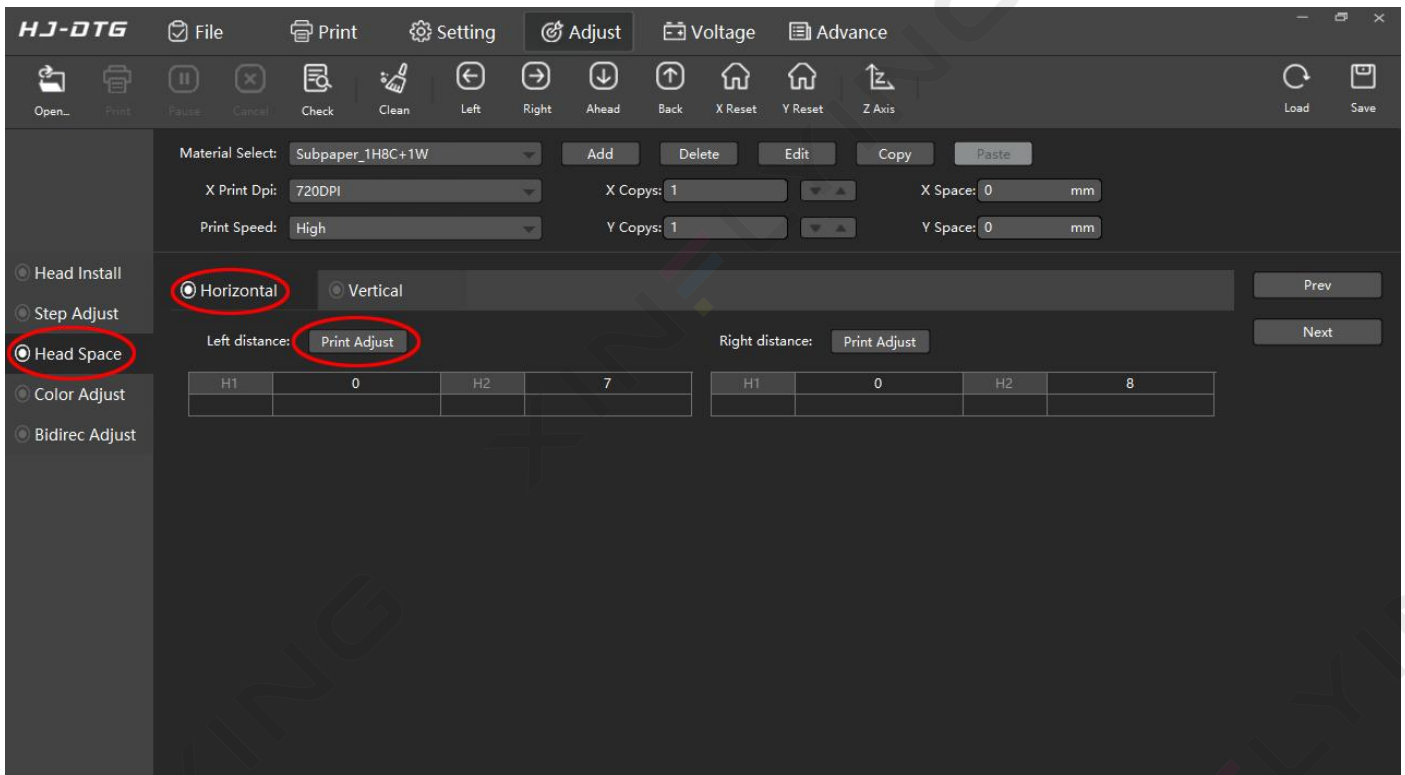

The printing effect is as follows (nozzle 2 is marked H2 on the far left of the calibration diagram)

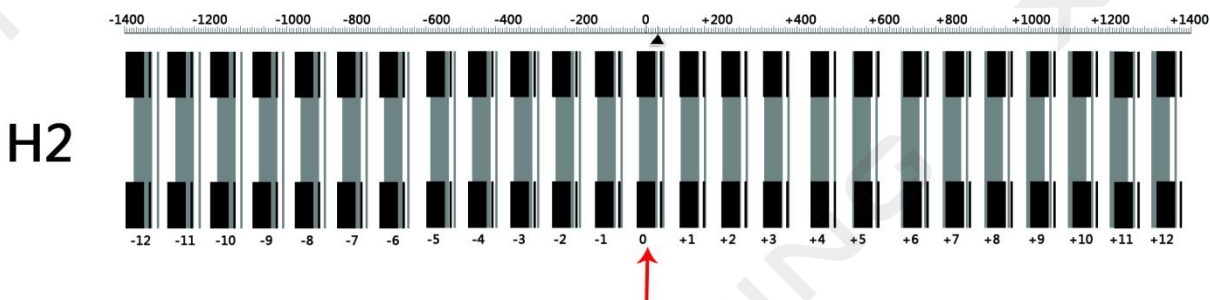

As shown in the figure, take 0 as the benchmark, the long arrow separates the lines, and adjust according to the '-' '+' symbol as indicated in the short arrow, + 4 lines, the left calibration of H2 number + 4 (column; the original value is 1417, changed to 1421) click the upper right corner of the software (nozzle H 2, H 3, H 4 need calibration, the right calibration mode is the same)

H2

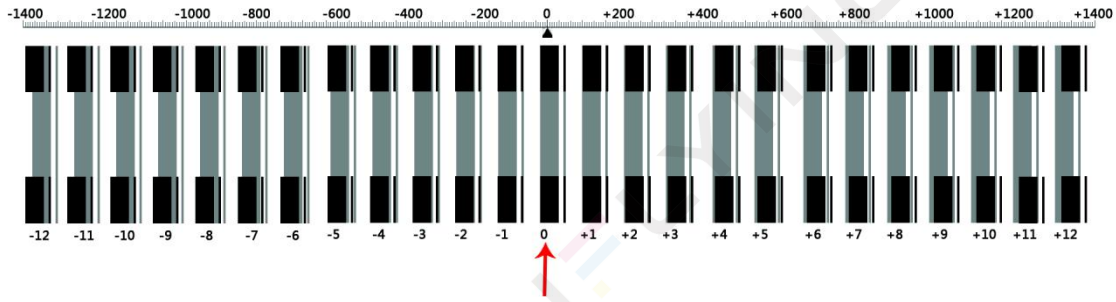

The above figure shows the calibration completion diagram

7.4 Longitudinal spacing calibration (the platform plate does not need to retreat to the inside, directly online)

(1) Click the "print calibration diagram" under the calibration box of the nozzle, and the system will print

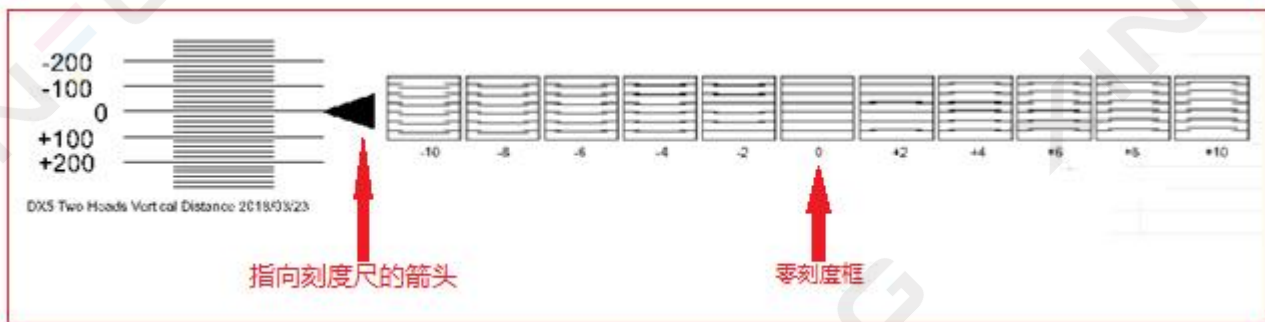

The above figure shows that the longitudinal distance between the sprinkler heads is normal, all the lines in the 0-point mark box are parallel, and the left arrow points to the 0-point mark line. If the longitudinal distance is not calibrated, the following figure will appear:

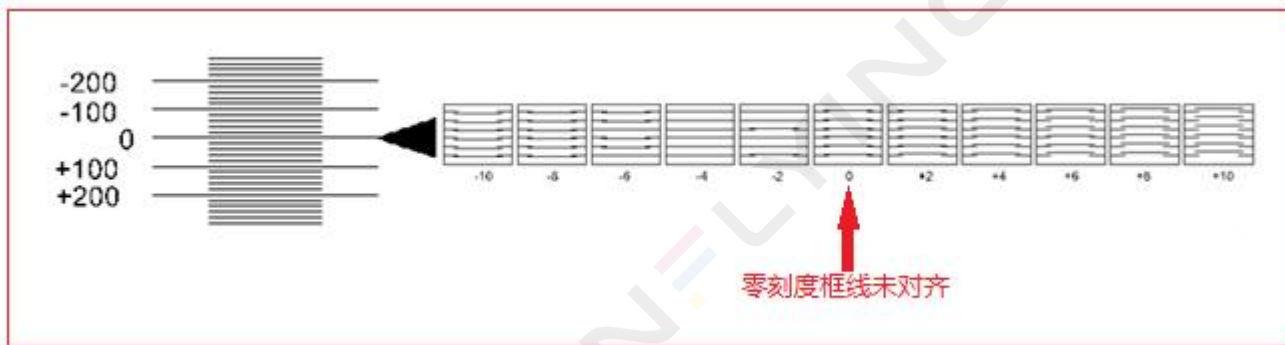

All the lines in the 0 point scale box above are not parallel, but all the lines in the -4 scale box are parallel, so it must be adjusted, reduce 4 from the benchmark of the original calibration value, and then recalibrate until all the lines in the 0 point scale box are parallel. The adjustment window is shown in the figure below:



7.5 Two-way calibration (the platform board does not need to return to the bottom, directly online)

(1) Click Calibration, select the two-way calibration, and click Print

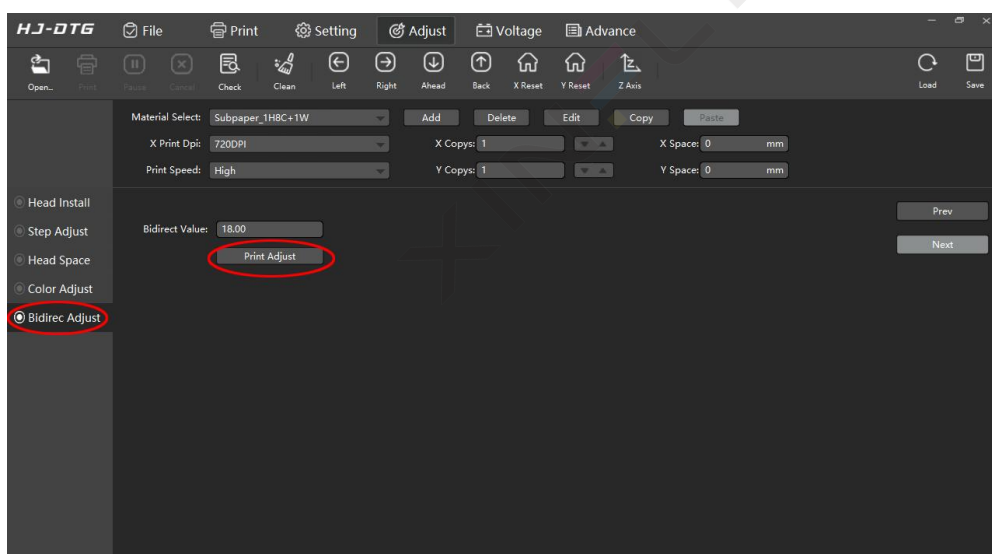

The arrow in the following figure indicates the standard point, and the number below the standard point is (0) Change according to the value input shown in the figure above. The two thin lines will overlap into one, that is, change the value to 8 (the original value is 12). After the value is adjusted, please click (save the parameters) and click bidirectional calibration again

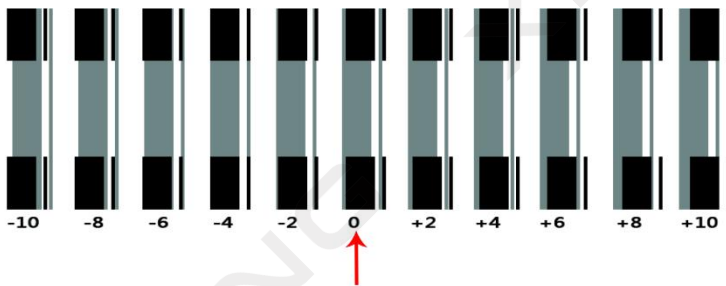

The following figure shows the two-way calibration completion map

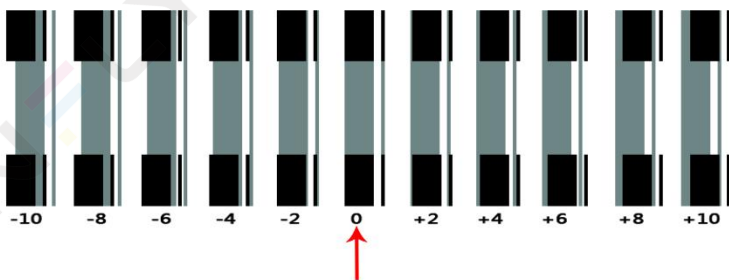

Chapter 8: Software Introduction

8.1 Introduction of the operation interface of the printing software

8.1.1 Main interface



The operation interface number corresponds to the icon function interpretation

Number 1 icon function to open the file (open the file done with the typesetting software RIP)

Number 2 icon function printing interface setting

Number 3 icon function base function setting

No.4 icon function nozzle calibration setting

No.5 icon function nozzle voltage setting, do not change without authorization, unauthorized change is not responsible for the company

Number 6 icon function advanced Settings, you can view the motherboard information

The number 7 icon function starts printing the selected task

The number 8 icon function stops the task in printing, which is also where to continue printing

Number 9 icon function cancels printing or waiting for printing task

No.10 icon function to print the status diagram of the nozzle to detect whether the nozzle is broken needle

No.11 icon function cleaning nozzle

Number 12 icon on flash spray or turn off flash spray

No.13 icon function set the current equipment Y and X axis parking place for the white edge, do not use at will

Number 14 icon function ink to move left (i. e. outward)

Number 15 icon function to move to the right (i. e. inward)

Number 16 icon function platform to move outward

Number 17 icon function platform moves inward

No.18 icon function X-axis reset (Jimo car reset)

No.19 icon function Y-axis reset (i. e. platform reset)

No.20 icon function Z-axis lifting control (Jimo car lifting)

No.21 icon function station selection (switch station 1,2 or duplex)

Number 22 icon function station alternate printing mode (optional on or off)

No.23 icon function table board selection (can be set according to the actual platform size, convenient to replace the table board switch)

No.24 icon function process setting

Process flow template process flow list click '+' and enter a name to create the process flow

Click '-' to delete the process flow

The process list can edit the content of the process process, and click "pressing" and click "-" at the top to delete this process (the pressing process cannot be used in this equipment)

Select 'Print' and click the right to enter the print process configuration

Channel control can only select the current process flow

Normal White color out with

Only Color Single play with color ink

Only White Singles with white ink

Multiple ink volume Color (color ink printing multiple setting, 1= normal, 2= double ink volume)

White (white ink printing multiple setting, 1= normal, 2= double ink volume)

The ink cutting setting can stop the amount of ink, column; the amount of white ink is set to 1. When the printing amount of ink is large, use the ink cutting setting to reduce the amount of white ink

K= black, C= blue, M= magenta, Y= yellow, and

R= red, G= green, and W1= white

Number 25 icon function Click on the arrow symbol to move the platform (Y1 platform)

Number 26 icon function Click on the arrow symbol to move the platform (Y2 platform)



No.27 icon function nozzle selection; 2HC (8C) _ 2 HW _ M

No.28 icon function routine setting; print speed setting when printing X direction speed (low speed, medium speed, high speed)

Print direction (left, right, bidirectional)

Flash spray before print (set flash spray on before printing or off before printing)

Automatic cleaning (set automatic cleaning on or automatic cleaning off)

No.29 icon function pressing; switch on or off (this function is not used on this device)

Time The time for pressing

Delay time pressing does not work immediately after receiving the instruction, later delay

Number 30 icon function white edge setting;

X white edge (adjustable printing, software calibration)

When calibrating the printing nozzle detection, it will print according to the setting of X and Y (not checked)

Y white edge (adjustable printing, Y direction start position during

calibration)

No.31 icon function color bar setting; color bar position sets the color bar position when printing (left color bar, right color bar, bilateral color bar, closed color bar)

Color bar mode can set the color bar as mode 1, mode 2, mode 3, the color bar style is different

The color bar concentration can be set to the color bar concentration (weak, medium, high-grade)

Bar width sets the width of the printed strip

The bar distance sets the blank distance between the bar and the pattern

Number 32 icon function automatically jump white; jump white way

Skip the map area by step print

Continuous white jump directly skip the no-map area

Close the white jump without map area to print normally, but do not ink

Automatic reset printing is automatically returned to the printing start position

Number 33 icon function feather setting; feather mode can be set to ordinary, mild, deep feather, closed feather, column; light feather printing speed is the fastest, deep feather is more delicate, and the printing speed is relatively reduced

Leaf type can be set to spray, spray reinforcement A, mixed, random and other types, different types, feather or wave

compensation procedures are different

No.34 icon function ink loading; nozzle selection can choose H 0, H 1, H2, H3, four heads for ink loading

Number 35 icon function advanced function; (image output per mirror) is not recommended

No.36 icon function standby regular cleaning; (if the equipment is completely powered on, it will be automatically cleaned)

The switch can be set on or off

Time can set the cleaning interval time

No.37 icon function standby timing flash injection; (if the device is fully powered, automatic flash injection)

The switch can be set on or off

Time can set the flash spray interval time

No.38 icon function loading parameters; refers to the parameters in the loading board card

Save parameter; change any parameter on the software interface, must click save parameter, otherwise the change parameter is invalid

8.1.2 Print interface (open the file to find a good RIP file, add to the task bar, right-click, and select Task Settings)

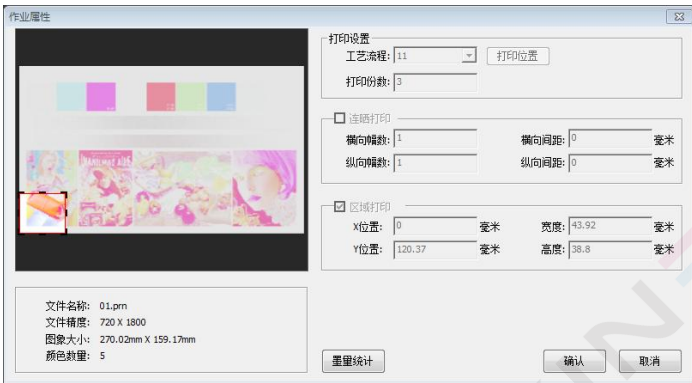

Print setting, process can choose the set process

Number of printed copies You can set the number of continuous printed copies

Print position can set the pattern output position

Continuous sun printing, horizontal amplitude number of horizontal printing amplitude number added

Vertical print number is added

Horizontal spacing the distance between the transverse after adding the number of amplitude

Longitudinal spacing: the distance between the longitudinal after the number of amplitude

Ink volume statistics to view the current pattern using the ink volume situation

Area prints a section on the printed image (customizable)

X position position on the image

Longitudinal position on the Y-position image

Width selected (width to be printed)

Height selected (height to be printed)

Task information, task name The task name matches the file name at RIP

Task accuracy is about to print the accuracy of the task

Image size The image size

Number of colors for several color channels

8.2 Calibration interface

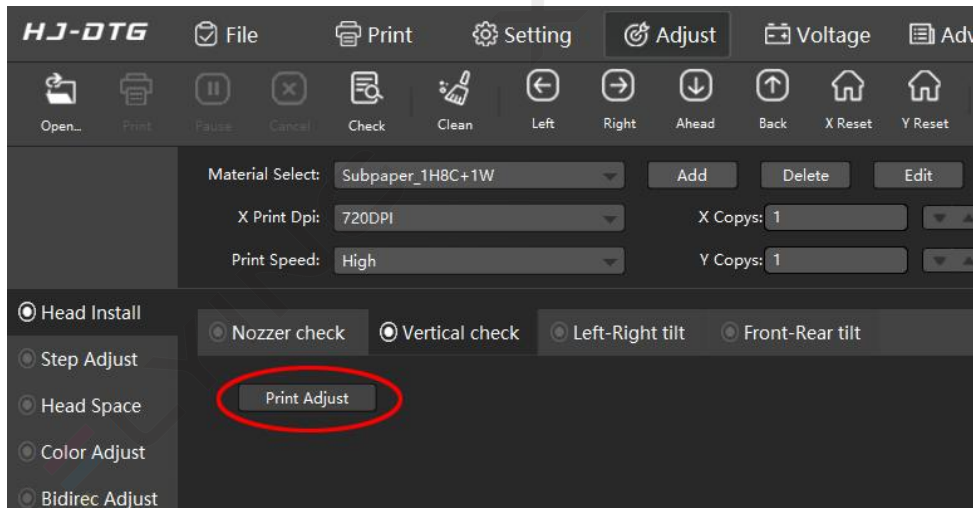

Head test, nozzle test, check the status of the nozzle test line

Check the nozzle horizontal status

Check the vertical state of the nozzle

Step calibration check Y axis step

Head spacing of the nozzle horizontal spacing calibration, calibration of the nozzle horizontal spacing

Calibration of nozzle longitudinal pitch

Color calibration nozzle set color calibration

bidirectional calibration calibration nozzle bidirectional

8.3 Voltage window



- Regulating voltage offset sets the offset voltage of the specified nozzle
- Refresh the voltage and updates the current nozzle voltage offset value
- Set the voltage to save the current nozzle voltage value
- Head temperature (read-only), indicating the specified head temperature
- (Do not change the voltage setting without authorization, and all consequences)

8.4 Advanced Menu

Click the main menu to enter the advanced interface, as shown below:

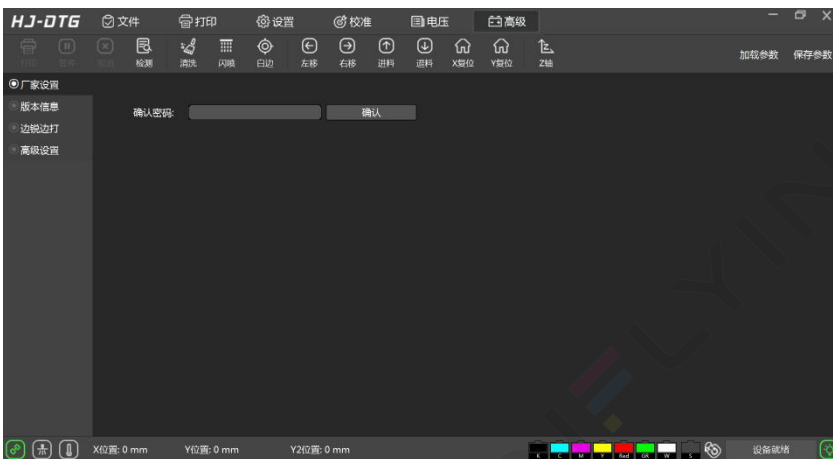

- Factory information into the entrance of the manufacturer's parameter setting
- Version information shows the relevant version information of the system board card
- RIP side playing side of the RIP side printing accuracy mode selection
- Advanced setting breakhole compensation, network configuration, installment authorization setting

Version 8.4.1 information

Click the version information in the advanced interface to enter the interface as shown below:

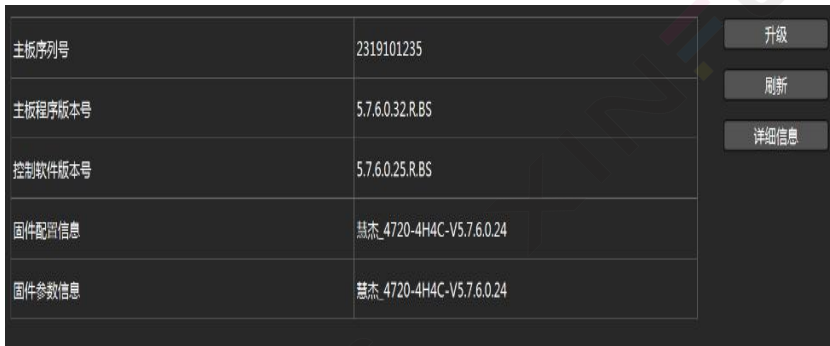

8.4.2 Broken hole compensation

In the Advanced Settings menu, click the Break Compensation button to enter the interface below:

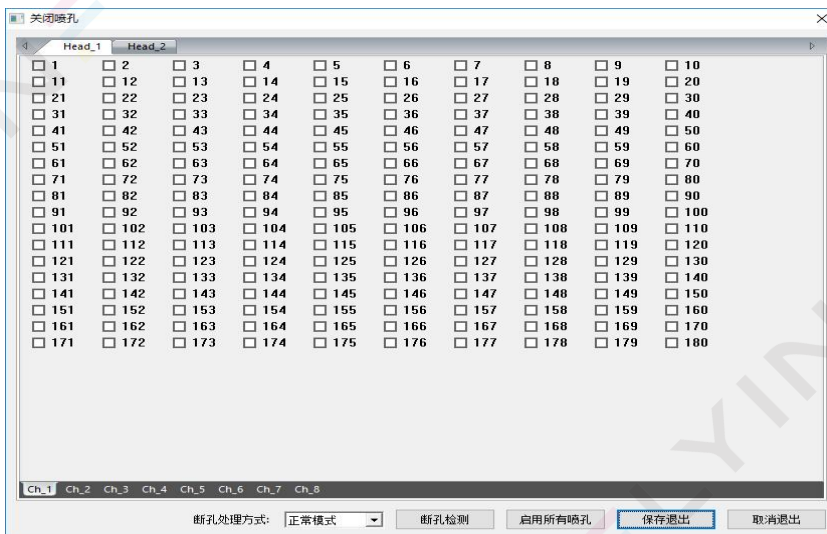

Break hole treatment method Break hole treatment method selection

Holhole detection detects the hole status of each row of nozzle

Enable all hole nozzle all vents enable / close selection

Save Exit Save the current settings and exit the hole settings status

Cancel to exit the current setting without saving, directly exit the break hole setting state

Press the right mouse button in the nozzle setting interface will pop the drop-down menu, as shown in the figure below:

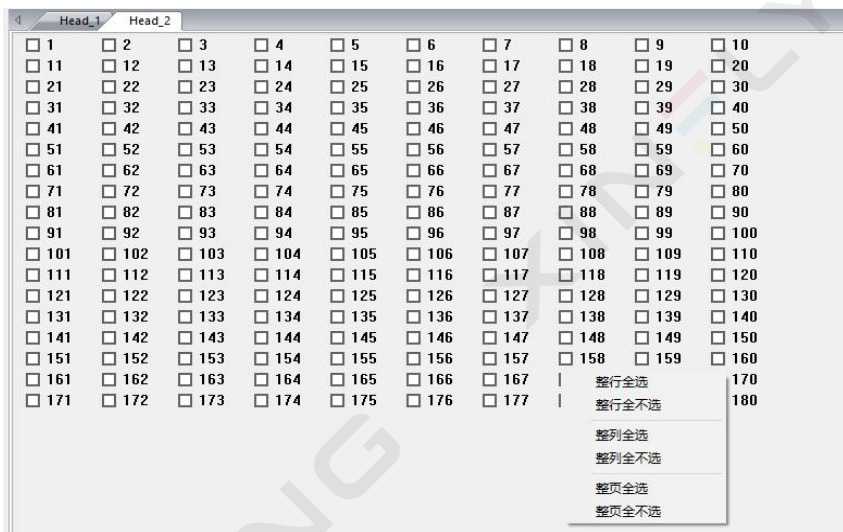

The whole line selects the whole line at the same time

The entire line is not selected to cancel the entire line

The whole column selects the whole column at the same time

The whole column is not selected and the whole column is simultaneously unselected

Select the entire page to select the entire page simultaneously

The entire page is unselected at the same time

8.5 Log

Click the log button in the lower right corner of the printing software to enter the log window, as shown in the figure below:



Through this window, we can see the current operation, especially when there is an error or fault. By viewing the debugging information, we can know which kind of error information is generated, so as to solve the error.

Chapter 9 Printing steps

9.1 Check the equipment

9.1.1 Check whether the nozzle test line is normal (white ink test line should be transparent, e. g.; film film, hot film, silver paper, etc.)



9.1.2 Check the nozzle height (the nozzle and printed cloth are 3MM)

9.1.3 Check the two-way calibration (spread the cloth on the platform plate and place A4 or A3 paper on the cloth for two-way detection)

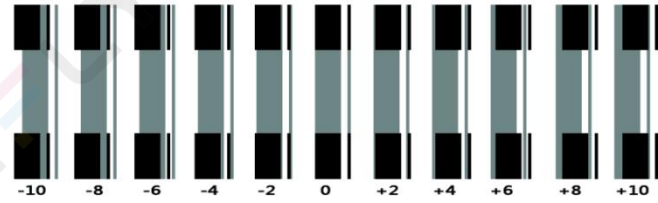
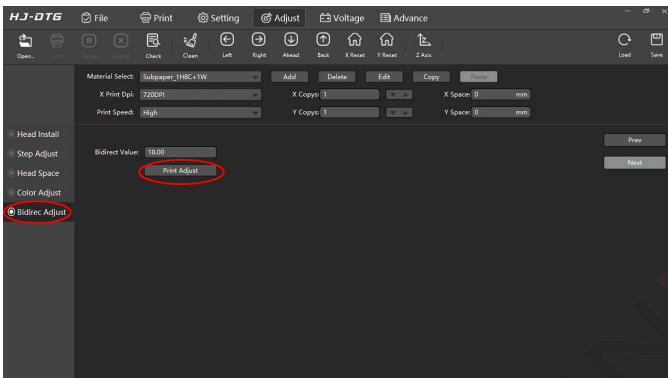

9.2 The RIP file

9.2.1 Use the typesetting software RIP image files for subsequent use

9.3 Pre-treatment of cloth (prepare a piece of waste cloth to test the pattern effect before formal printing. The waste cloth should be the same as the formal printing cloth)

9.3.1 Clean the foreign matter on the cloth (wool ball, thread head, the rest of the cloth, etc.)

9.3.2 The temperature of the pressing machine is 170°C, with a clean pressing paper on the cloth. The pressing time is 10 seconds (the pressing temperature and time are adjusted according to the cloth)

9.3.3 Check whether there are sundries and water in the spray gun pot, whether there is foreign body blocked in the nozzle, adjust the spray gun into a vertical shape, and add the pre-treatment liquid for pre-spray (align the cup with the nozzle mouth and pre-spray for 3 seconds to prevent the large drop treatment liquid from dripping on the cloth during formal spraying)

9.3.4 The nozzle is tilted at 45° Angle, 25 to 30 cm high. According to the size of the pattern, the top, from left to right two uninterrupted uniform spraying, and the spray amount of cloth 21 is about 20~25g (the spray amount is more or less according to the cloth and pattern, the above standard pattern size is A4)

9.3.5 pressing machine 170°C, pressing paper is placed on the cloth for pressing, pressing time is 15~60 seconds, the pressure is reduced, and light pressure is used.(In two ~ three times of pressing, pressing time, temperature according to the treatment liquid, cloth adjustment) after pressing drying cloth flat stacked together, or use a thousand layer frame placed separately, can not appear wrinkled

9.4 Print

9.4.1 Open the device operation software, select the file, find the storage location of the previous RIP file, and the name, and double-click to open it

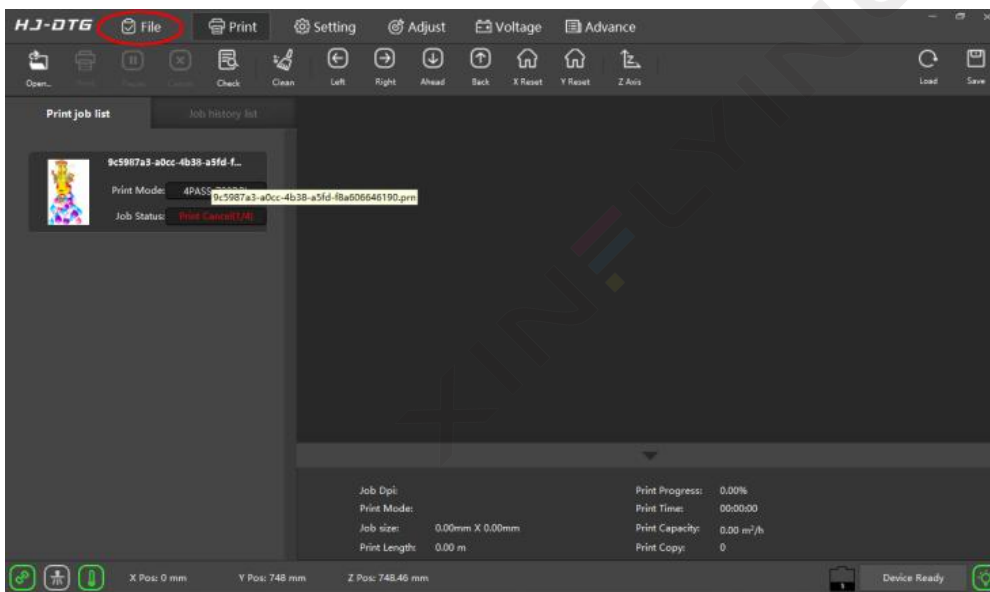

9.4.2 Right-click on the task to select Task Settings

Position adjustment, process selection, etc. For details, please go to chapter 99.1.2.

For details of process setting, please refer to chapter 99.1 printing software operation interface, number 24 icon function

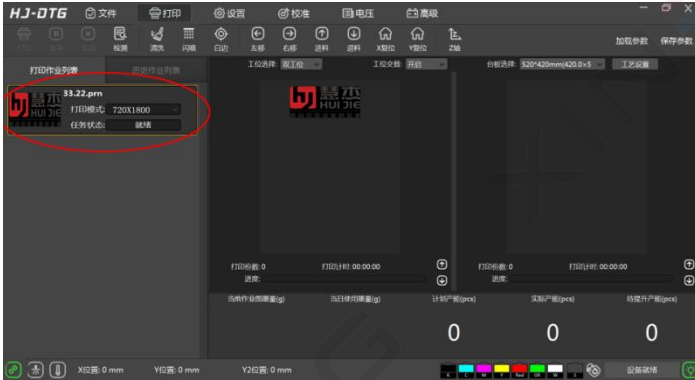

.4.39 Spread the pretreatment waste cloth on the platform board, and click to print (the cloth can not be arched, otherwise it is easy to rub against the nozzle)

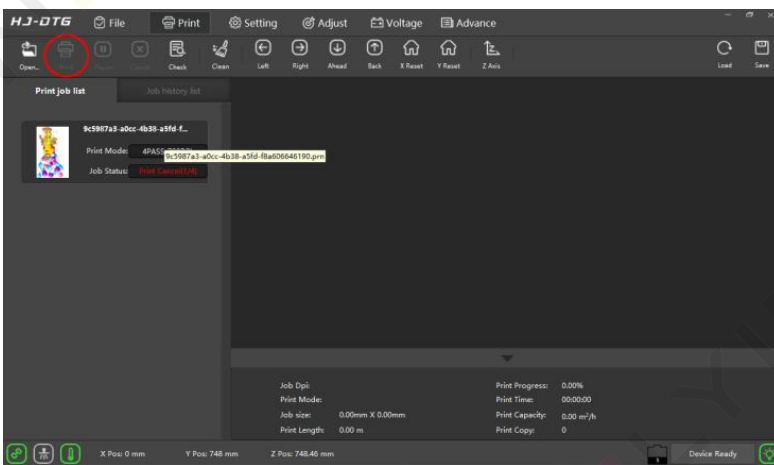

.4.49 After waiting for the signal light on the equipment to light the yellow light, manually press the start button, the button is in front of the plate, which plate the cloth is laid, that is, press the corresponding button to start printing

.4.59 After printing, use the hot air gun to move up and down from 20CM and blow for 30 seconds until the table is dry (the time is controlled according to the ink and

cloth) or for 4-5 hours before drying.

Tunnel furnace 160°C drying for 3 minutes (temperature and time adjusted according to ink and cloth)

Press 170°C press paper for 3 minutes (press temperature, time according to ink, cloth)

Chapter 10 Daily Maintenance

.110 Machine maintenance

10.1.1 The appearance and working environment of the machine are clean, and the dust entering the machine will increase the internal resistance of the machine running, and shorten the use of the machine.

10.1.2 Do not place other objects other than the printing media on the machine to avoid accidents.

10.1.3 Clean the guide rail in time without oil and dust to prevent entering the sliding parts.

10.1.4 Clean the grating strip with clean dust-free cloth to prevent dry ink from causing failure. If it is dry, it can be gently scrubbed back and forth with medical alcohol. **Note: No industrial alcohol to use**

10.1.5 Add appropriate lubricating oil to the moving parts of the equipment to include:

The rail rail for the X-axis trolley

The rod and guide rail inside the Y axis module

10.1.6 Clean up the waste ink cartridge once a week. Remove the scrap ink from the scrap ink cartridge.

10.2 nozzle maintenance

10.2.1 Pay attention to the humidity and temperature of the environment. If the temperature is too high, the ink dries up quickly, which affects the printing quality and is easy to plug the nozzle.

10.2.2 The nozzle should be returned to the cleaning station in time when it is not used. It is strictly prohibited to expose the nozzle in the air for a long time.

10.2.3 Once the ink absorption pad is aging, please replace it in time, otherwise the nozzle will be dry and damaged due to poor sealing.

10.2.4 Print the nozzle status chart before each shutdown, and then down the nozzle after confirming the status map is complete.

10.2.5 Start up and print the nozzle status diagram every day. The firm status diagram is complete.

10.2.6 Ensure that the nozzle trolley is reset, enters directly above the ink stack, and conducts cleaning operation;

10.2.7 When the machine is not working, all switches shall be adjusted to the closed state, and the circuit breaker switch outside the electric control box shall be switched to the OFF state;

10.2.8 If the machine is not used for a long time, please turn it on every day, print a picture or the nozzle status map, so that the ink can flow. (Not for 4 days, to

spray the head status chart every day.5~9 days do not use, to seal the cartridge inlet and the waste ink pipe, with the clip belt to ensure that the nozzle car reset, into the ink stack above the fixed moisture.10 days, to remove the nozzle and clean, put it in the fresh cabinet.)

10.2.9 Cover up the machine for a long time, and do the daily maintenance work of the machine in time.

Life: clean the nozzle with the ink absorber or replace the nozzle

(If you have any questions or are unclear, please contact Huijie after-sales service. Tel.: 02031000391)

Chapter 11, Common faults

.1 11 Error printing



11.1.1 Generally displayed in the lower right corner of the printing software interface. Click on the lower right corner will pop up the error report. Then solve the problem based on the information and solution in the error report.

.211 Clean the nozzle out of the waste ink

11.2.1 Check whether the ink pump motor is not working and whether it will rotate.

11.2.1 Check the orifice surface and ink absorption pad of the nozzle, and seal without air leakage

11.2.3 Check whether the waste ink silicone tube between the ink pump and the ink suction pad is rotten or perforated

11.2.4 Replace the new ink absorption pad

.3 11 A replay appears when printing the picture

11.3.1 Check whether the distance between the printed material surface and the nozzle is 3MM.

11.3.2 Check the bidirectional calibration diagram and recalibrate the bidirectional diagram.

.4 11 Picture printed with pull

11.4.1 Check whether the nozzle status is broken ink

11.4.2 Check the status of the nozzle for ink string

.5 11 There is a broken square ink when printing the pattern

11.5.1 Grating graft, need to use a cotton swab with water to scrub the upper and lower grating, should be wiped several times after washing

Dry the water.

11.6 Misalignment when printing patterns

11.6.1 Belt wipe the pulley card, adjust the pulley;

11.6.2 When the servo motor is broken, the servo motor needs to be replaced;

11.6.3 Calibrate the spray nozzle.

11.7 The nozzle does not give ink

11.7.1 If the nozzle line is aging, the nozzle line should be replaced.

11.7.2 If the nozzle is blocked, it shall be cleaned.

11.7.3 The ink pipe interface is blocked and needs to be unplugged and cleaned.

11.7.4 Spray nozzle interference, swap the nozzle position, and use a paper towel pad between the nozzle and the row line

To check that it is the nozzle interference, replace the nozzle.

11.7.5 Decryption card flashing red light, need to replace the decryption card.

11.7.6 If two sprinklers are not ink at the same time, after eliminating the interference of the nozzle, it is not ink namely

The car board is broken.

11.8, startup failure

When starting up, the car frame hits the left frame

11.8.1 The grating sensor is dirty and should be cleaned;

11.8.2 The grating sensor is broken and needs to be replaced;

11.9 Print accuracy problem

Printed images are stained or difficult to melt, usually as two colors stain each other

11.9.1 Poor medium or already damp: keep the medium dry or replace the medium

well

11.9.2 Poor ink quality: replace the ink

11.9.3 Reduce the inkjet amount of the machine

11.9.4 Image output with striped nozzle plug or reach life: clean the nozzle with an

ink absorber or replace the nozzle