

450S

3-head UV Pinter

Instruction Manual

c



XINFLYING

Reliable & Professional Printing Machine's Supplier Since 2010

○ Thank you for purchasing this product
Please read this manual carefully before use ○ Please keep this book properly

Catalogue

1. Introduce.....	3
2. SAFETY INSTRUCTIONS	4
3. Preparations and Precautions	6
3.1. Unpacking Your Printer	6
3.2. Required Printing Environment Condition.....	6
3.3. Electrical Requirements	6
3.4. Computer configuration requirements	6
3.5 Precautions	7
4. Product Introduction	8
5. Model specification	8
6. Product show	9
7. Software Installation and Set up	9
7.1 Printing software installation	9
7.2 Connect Gigabit Network Cable	11
7.3 Set the online IP address of the printing software	11
7.4 RIP software installation	13
8. Printer Installation and Pre-print Debugging	14
8.1 Horizontal Calibration	14
8.2 Ink Tank Connection	15
8.3 Print Head Installation position and cable connection	15
8.4 Damper Installation	20
9. Power-on inspection	20
10. Debug Before Printing	20
10.1 Confirm ink stack and cleaning parameters	20
10.2 Print Nozzle Test & Confirm the status of Print Head	21
11. Alignment & Calibration	23
11.1 Vertical Alignment Of the Print Head	23
11.2 Step calibration	23
11.3 Calibration of nozzle horizontal space	24
11.4 Nozzle vertical space calibration	26
11.5 Bidirectional printing calibration	27
12. Precautions & Maintenance	30

1. Introduce

Dear Sir/Madam:

Thank you for choosing our products, we are a highly professional and reliable supplier of DTF printer.

DTF printer is an advanced technology product that has developed rapidly in recent years. In order to help our users better operate the machine and ensure its normal operation, this manual will provide detailed instructions on how to use, maintain and precautions of the DTF printer. Please read this manual carefully before using the machine and follow the guideline for proper operation. If you have any questions, please contact our technical engineers for guidance. This equipment is suitable for temperature of 20 ~ 35°C/68 ~ 95°F and humidity levels of 35 ~ 70%RH, which can improve production efficiency and product quality.

This manual is only the product usage instructions. If there are any upgrades to the machine, we will not notify separately. If you have any good suggestions for this product, please provide feedback to the agent so that we can get the information in time and make better improvements to the machine

Thank you!



2. SAFETY INSTRUCTIONS

2.1 Safety indications and their meanings

This instruction manual and the indications and symbols that are used on the printer itself are provided in order to ensure safe operation of this printer and to prevent accidents and injury to yourself or other people.

The meanings of these indications and symbols are given below.

Indications

	DANGER	The instructions which follow this term indicate situations where failure to follow the instructions may result in death or serious injury.
	WARNING	The instructions which follow this term indicate situations where failure to follow the instructions can result in severe injury or death.
	CAUTION	The instructions which follow this term indicate situations where failure to follow the instructions could cause injury when using the machine or physical damage to equipment and surroundings.

2.2 Note for safety

Symbols This symbol () indicates something that you should be careful of. The picture



.....

inside the triangle indicates the nature of the caution that must be taken.

(For example, the symbol at left means "beware of injury".)









.....

This symbol () indicates something that you must not do.



.....

This symbol () indicates something that you must do. The picture inside the circle indicates the nature of the thing that must be done.

 DANGER	
 Wait at least 5 minutes after turning off the power switch and disconnecting the power cord from the wall outlet before opening the cover of the control unit. Touching areas where high voltages are present can result in severe injury.	
 WARNING	
Basic precautions	
 Do not disassemble or modify the printer, otherwise it may cause fire or electric shocks or problems with correct operation.	 Do not handle the power cord with wet hands, otherwise it may cause electric shocks.
 Ask the place of purchase or a qualified technician to carry out any internal inspections, adjustments or repairs that may be required. (Any problems with correct operation that occur as a result of the customer attempting to disassemble or modify the printer will not be covered by the warranty.)	

(For example, the symbol at left means "you must make the ground connection".)



CAUTION

Installation



Setting up and moving of the printer should only be carried out by a qualified technician.



The printer machine weighs approximately 150 kg. Transporting and setting up of the printer should be carried out by four or more people. Furthermore, do not hold the printer by the ink cartridge housing when transporting it, otherwise the ink cartridge housing may become damaged and the printer may fall down and cause personal injury or damage to the printer.



Do not place the printer on unstable surfaces such as unsteady tables or high shelves, otherwise it may tip over or fall down and cause injury. Furthermore, the table that supports the printer should be able to bear a weight of 150 kg or more.



Do not set up the printer in a place where it will be affected by vibration from other equipment, otherwise it may become unbalanced and fall down and cause injury or damage to the printer.



Do not connect the power cord until setup is complete, otherwise the printer may operate if the power switch is turned on by mistake, which could result in injury.



Do not climb onto the printer or place heavy objects on top of it, otherwise it may become unbalanced and tip over or fall down and cause injury.

Printing



This printer should only be used by operators who have received the necessary training in safe use beforehand.



Leave sufficient space at the front of the printer, and avoid placing items in front of it, otherwise the platen may hit them and be damaged, and if your hands get caught between the platen and the object, injury may result.



Release your hand from the platen while the printer is operating. If your hand gets caught between the platen or the T-shirt tray and the covers, injury may result.



Do not push nor pull the platen by hands quickly. It must be a cause of operation troubles or failures of printed circuit boards.



Do not put your hands inside the covers while the printer's power is turned on, otherwise your hands may touch against moving parts and this may result in injury.



If a problem occurs with the operation of the printer, contact the place of purchase or a qualified technician.

Maintenance



Wait at least 1 minute after turning off the power switch before opening the front cover. Touching the heat sink on the head can result in burns.



Be careful not to get your fingers caught when closing the front cover, otherwise it may result in injury to your fingers.



Do not push nor pull the platen by hands quickly. It must be a cause of operation troubles or failures of printed circuit boards.



Do not disassemble the ink cartridge or the waste ink cartridge. If the ink cartridge or waste ink cartridge is disassembled, it can no longer be used.



Take care not to let the ink, waste liquid or wash liquid come into contact with your eyes or onto your skin, otherwise inflammation can result.

Furthermore, do not drink the ink, waste liquid or wash liquid under any circumstances, as they can cause vomiting and diarrhoea.

Keep the ink, waste liquid and wash liquid out of the reach of children.



Use only the proper replacement parts as specified by Xinflying.

3. Preparations and Precautions

3.1. Unpacking Your Printer

After unpacking, check all your parts are included.
Contact XINFILYING if any of these is missing.

3.2. Required Printing Environment Condition

The printing environment request 20°C-35°C (68°F - 95°F) and 35-70%humidity.

3.3. Electrical Requirements

Please check whether your printer's voltage is match your voltage that your country use. If it doesn't match, it will lead to an explosion!

3.4. Computer configuration requirements

Computer system:

Windows10/64 -bit, Windows11/64 -bit.

CPU configuration:

Use i5 or above i5 CPU.

Memory stick:

8G or above

Power supply:

500W or above

Motherboard:

Configure the USB 3.0 port, gigabit network card

Network card and network cable requirements:

Gigabit or above network card must be used, and the network cable needs to be super Category 6 or above to support dry-mega communication network cable.

Hard disk configuration:

It is recommended to use a 120G solid state hard disk as the system disk, and then add a mechanical hard disk (1TB) as a secondary disk as needed.

Based on PCIe system, Asus / Gigabit etc.

3.5 Precautions

1. The machine foot holder cup must be secured to keep the machine level to ensure that the machine does not shake.
2. Do not let liquids come into the print head and cables, as it can damage the print head.
3. Avoid scratching the print head with the printing film, as it can be fatal to the print head.
4. Before shutting down, check if the trolley is reset to ensure the print head is in the optimal position (in the middle of the ink pad). The print head must be aligned with the ink pad to maintain moisture and prevent clogging.
5. The print head cable must be correctly connected and double-checked before starting the machine. Send pictures or videos of the cable connections to the technicians. Incorrect connections can damage the print head or head board.
6. After turning on the machine, please open the white ink circulation system and let it run for 2-3 minutes before closing. This effectively prevents the formation of bubbles in the ink tubes.
7. Do not let the pet film scratch the printer head, which is deadly for heads. So the press clips on both sides of printing platform should be pressed onto printing film, covering a space of 2-3mm.
8. Keep consumables away from direct sunlight and humid environment. For optimal printing results, it is recommended to use them within the warranty period, which is one year.
9. Ink can cause ink tube blockages. To avoid this, open the printer at least once a week and clean the print head by pressing the nozzle cleaning button. If you plan not to use your printer for more than two weeks, follow the maintenance manual to prevent ink blockages.
10. The Color Bar should be set "Wetting" by the software to prevent the print head from clogging.
11. Do not unplug any wires from the machine while it is powered on, as it can damage the boards and print head.
12. The machine must be grounded to prevent ink splattering or damage to individual ink dots on the print head.
13. Do not manually cut printing film on the machine with a knife or other sharp article, as it can cause scratches and affect the appearance of the machine.

4. Product Introduction

The Transfer Printing White Ink Machine, which uses Epson I3200-A1 print head with high precision, high efficiency, and finer colors. The product supports personalized customization for DIY purposes and has a wide range of applications. The machine is easy to operate and maintain, equipped with a white ink circulation system to ensure smoother ink flow and prolong the life of the print head.

5. Model specification

Model Type	450S
Print head and Quantity	I1600-A1 3pcs, I3200-A1 3pcs
Printing Resolution	720x1800
Printing Speed	I3200-A1:4pass:12m ² /h 6pass:10m ² /h I1600-A1:4pass: 10m ² /h 6pass:8m ² /h 12pass: 2m ² /h
Printing Width	300mm
Media Type	Pet film
RIP Software	Standard software: Maintop; Optional: PrintFactory, Photoprint(Flexi)
Temperature/Humidity	Temperature: 20-35°C/68 ~ 95°F, Humidity: 35-75%RH
Power	1500W
Machine Dimension	Machine size : 1240mm*700mm*1500mm(L*W*H) Package size : 1350mm*750mm*750mm(L*W*H)
Machine Weight	Weight: 100KG

6. Product show

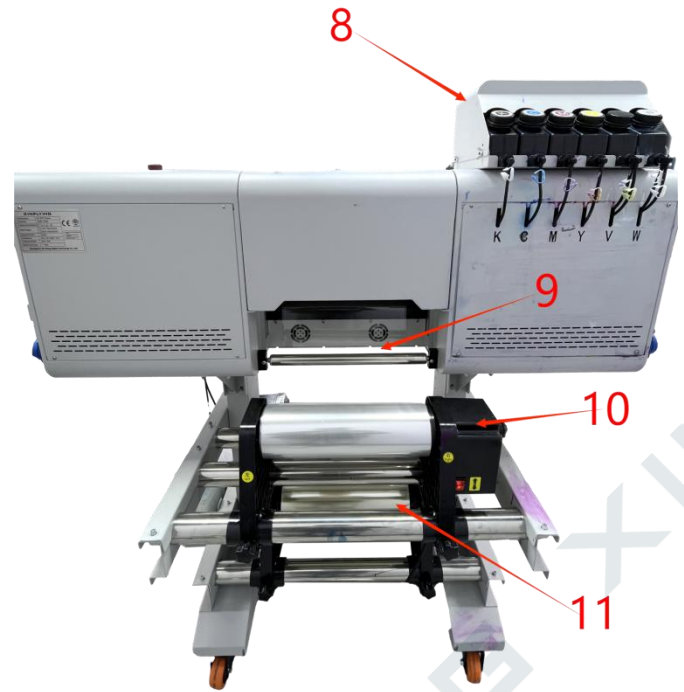

NO.	Name	NO.	Name
1	Ink cartridge shelf	7	Paper rewriter
2	Emergency stop switch	8	CMYKWV Ink cartridge
3	LED digital display screen	9	Film pressing rob
4	Control panel	10	Paper rewriter
5	LED light switch	11	Paper feeder
6	Fan strength knob		

7. Software Installation and Set up

7.1 Printing software installation

1) Unzip the installation package to find the installation file.

名称	修改日期	类型	大小
PrintExp_V5.7.6.5.76.Single_20230425(...	2023/12/26 15:56	文件夹	
PrintExp_V5.7.6.5.76.Single_20230425(...	2023/7/5 9:51	WinRAR 压缩文件	21,625 KB
PrintExp_V5.7.6.5.76.Single_20230425	2023/6/5 17:20	应用程序	208,351 KB

2) Select the language and set the installation path

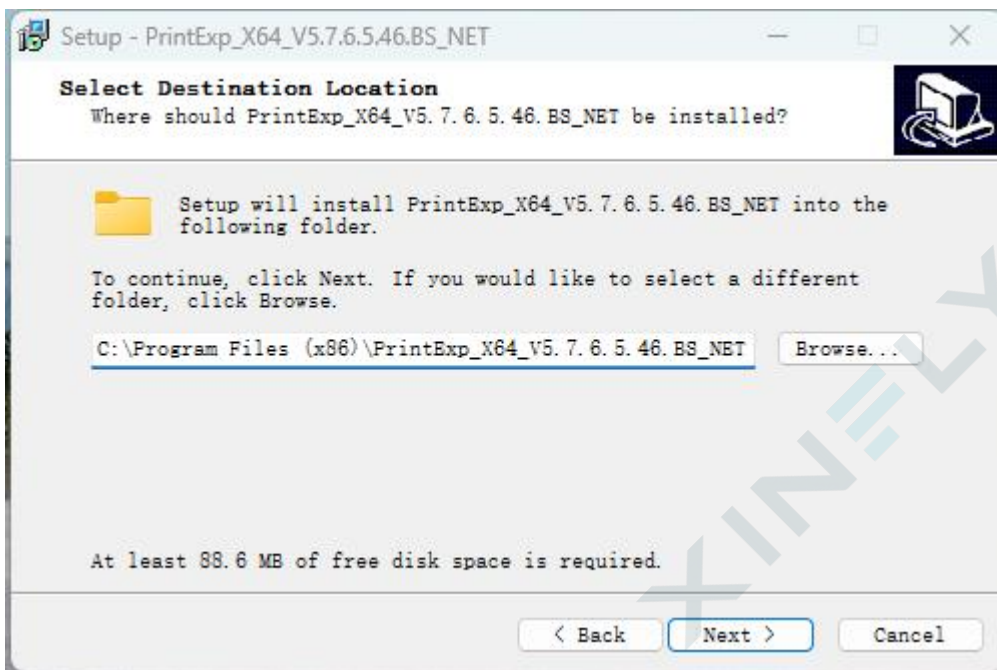
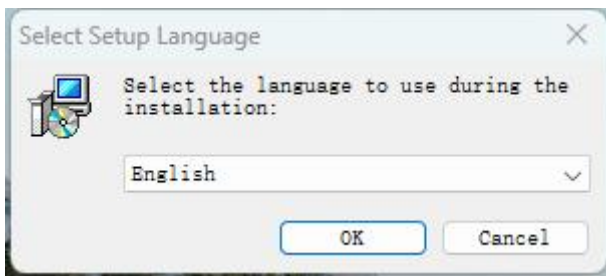

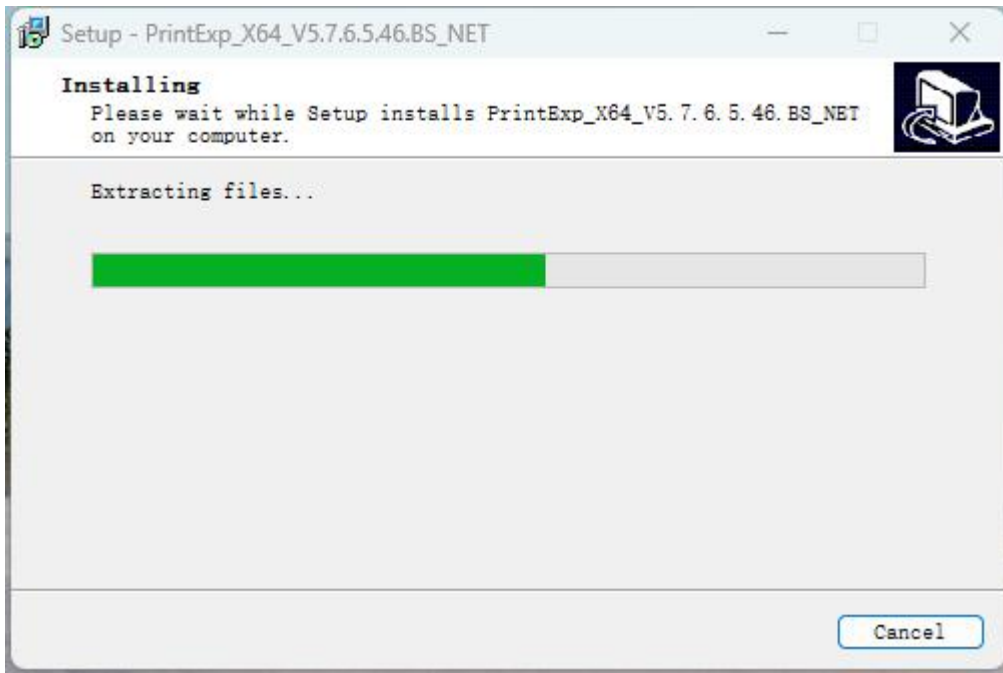

3) Create a desktop shortcut.

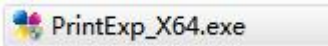

7.2 Connect Gigabit Network Cable

We will equip the machine with a gigabit network cable. Then we connect one end of the gigabit network cable to the network port of the printer motherboard, and the other end to the network port of the computer host.

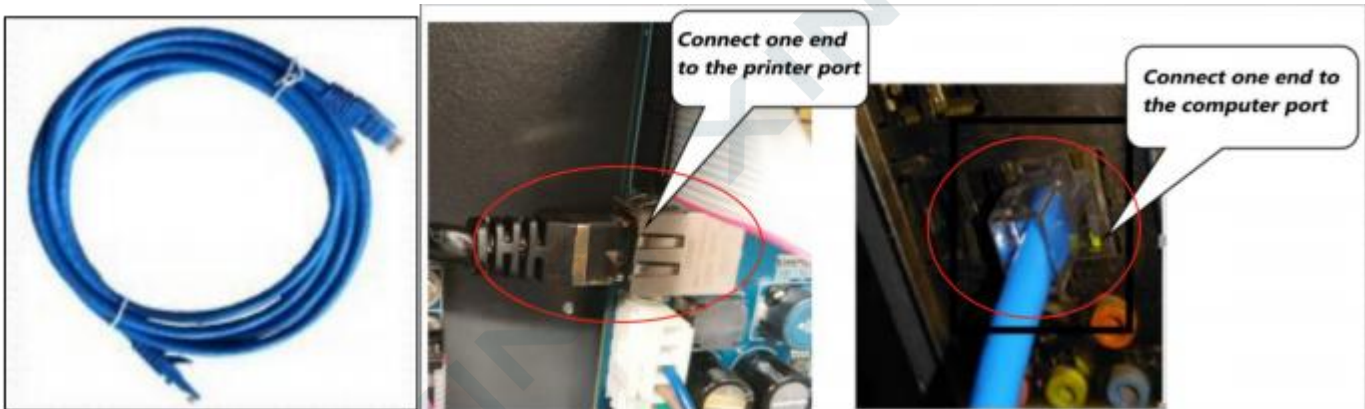

7.3 Set the online IP address of the printing software

Before connecting to the network, please check if your computer is equipped with a gigabit network card to ensure a smooth connection. The difference between a gigabit network card and a 100Mbps network card is as follows: Gigabit network cards usually have the following

characteristics: Gigabit, GBE, 10/100/1000M, RTL8169.

100Mbps network card contains the following characters: Fast Ethernet, 10/100, FE.

Enter the computer's device manager to check the network adapter.

The control software version must match the board version. After installing both the control software and RIP software according to the instructions in the installation package, you can configure the IP settings for networking. Here are the steps to follow: Open the software → Network and Internet setting → Communication set → TCP communication → Enter the local host IP: 192.168.127.11 → Control Panel → Network and Internet → Network connections → Right-click on 'Properties' → TCP/IPv4 → Click on 'Properties' → Check 'Use the following IP address' and modify the IP address to 192.168.127.11. (About this, we have a tutorial introduction document we sent to you)

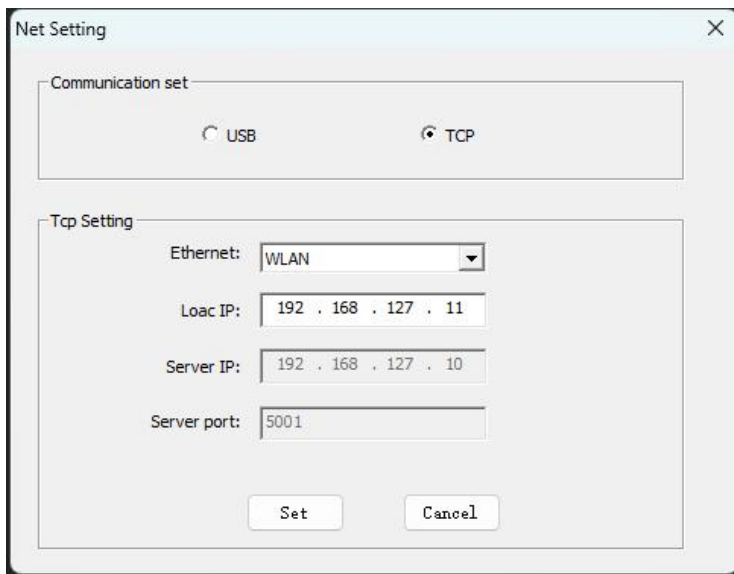

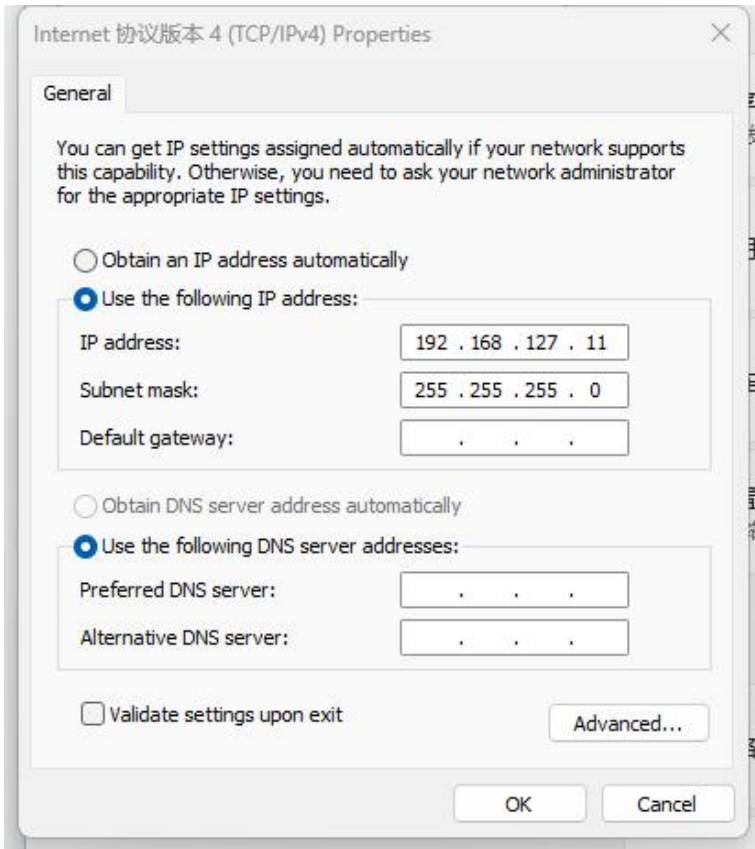

7.4 RIP software installation

The DTF printer mainly uses RIP software, which includes Maintop, PrintFactory, Photoprint(Flexi). This chapter will use Maintop as an example to introduce the installation method of RIP software.

1. Extract the installation package and locate the installation file

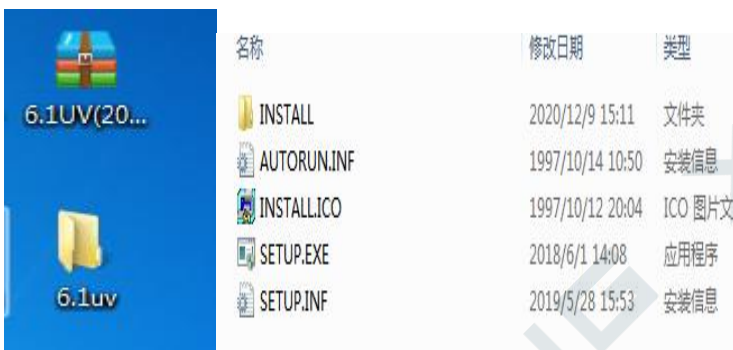

2. Set the installation path and wait until the installation is complete.



3. Finish the installation and create a desktop shortcut.



8. Printer Installation and Pre-print Debugging

8.1 Horizontal Calibration

Fix the foot cup and use a level to align the steel pipe. The calibration of the printing platform should have an error value within ± 0.1 to prevent material deviation. Please refer to the picture for details.

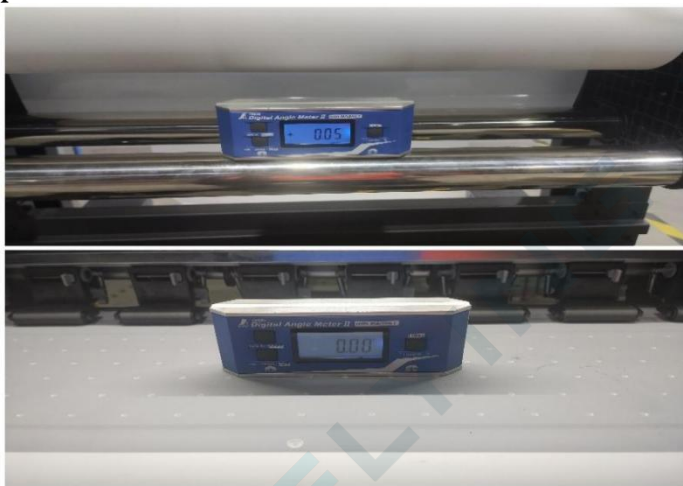

8.2 Ink Tank Connection

1. Install and tighten the screws on the ink cartridge, then put the ink cartridge in order, connect the ink tube to the corresponding color ink tank, and insert a clip in the middle of the ink tube (The clips can be used for the printer after disconnecting the power, the clip clamps the ink tube to prevent ink from flowing and leaking).

Note: No adding ink when the ink tube and damper are not connected.

Remember to clip the ink tubes.



8.3 Print Head Installation position and cable connection

Take out the print head and its cover, use a syringe insert into the four ink holes above the print head respectively. Gently flush out the moisturizer inside the print head. Gently wipe the surface of the print head with a dust free cloth, install back the print head cover. Connect the print head cable, and stick the connection between the cable and the print head with special waterproof tape. Gently align the print head with the holes and screw it, the screws are just tight enough.

NOTICED:

- ① **You can't use a large syringe, use a 2.5ml small syringe to lightly flush out the moisturizer. Cleaning the print head also use a 2.5ml small syringe.**
- ② **The cables should be aligned and inserted with appropriate force. Don't use excessive force or insert it crookedly, and make sure it is not inserted in the wrong orientation.**
- ③ **When connecting the cables, pay attention to whether the metal part of the cable is bent or broken.**
- ④ **DO NOT scratch the surface of the print head to prevent damage to the print head;**

Note that the bottom of the print head should not be touched (Red circle mark is the bottom of the print head), because the bottom of the print head is very fragile.



⑤ The screws on the print head should be properly tightened, and DO NOT tighten too much to prevent damage to the screw holes and damage to the print head.

1. Installation of the cables, the print head should be connect with two 14P cables on the left and the right.

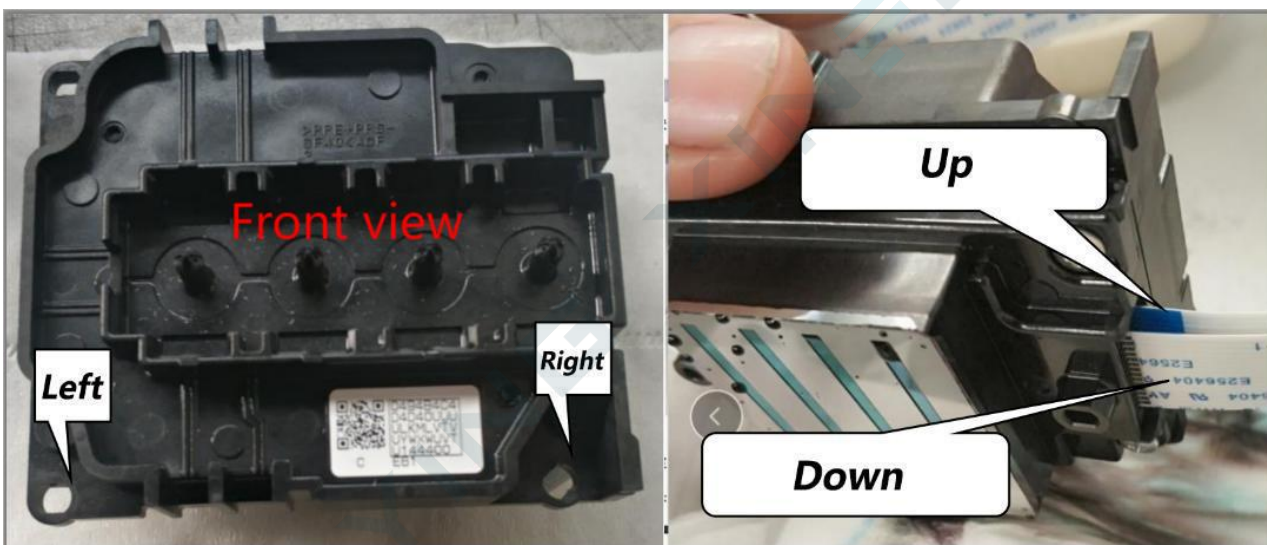

(Note: Be careful when plugging in, so as not to damage the print head or the cables!)



2. Install the print head

Put the print head steadily to the left and back, close to the bottom plate, and install and secure it. (Note: Do not tighten the print head mounting screws too hard)



Schematic diagram

The order of cable connections corresponds to the markings on the cable headboard and the print head.

(Note: When plugging or unplugging the print head cable, do not turn on the printer. Please remember that reversing the cable of the print head is not allowed as it will damage the print head!)

I1600 print head

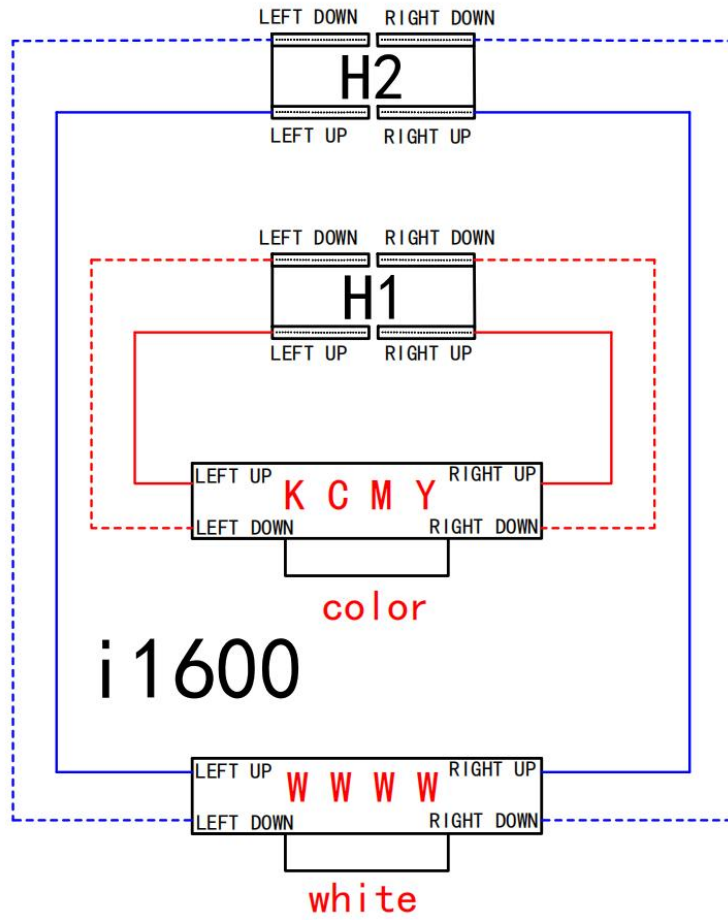

I3200 Print head



Correct(metal part to metal part)

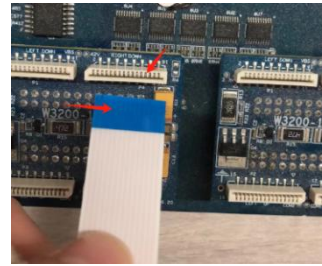

Incorrect

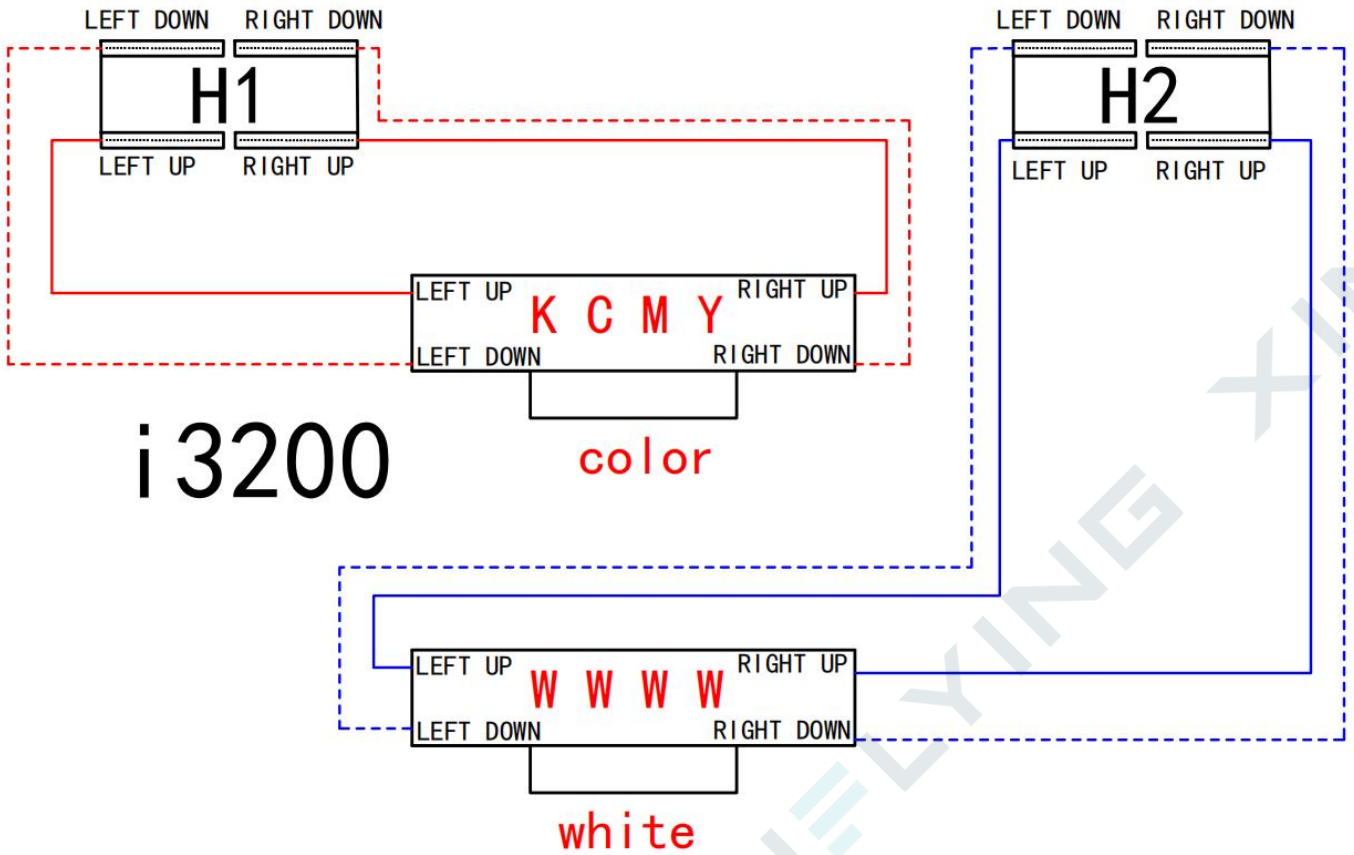

After confirming the print head's cables are connected correctly, (You need to take photos or record video to our technicians for checking so that you can turn the printer on! .

8.4 Damper Installation

Take out the damper. Install the color print head's dampers in the order of KCMY (black, cyan, magenta, and yellow); There is no specific order for the white ink dampers; After adding ink to the cartridge, use a syringe to remove any air bubbles and ensure that the ink flows smoothly into the damper and tube. Align and place well the dampers into the print head, and install it with appropriate force.

① **Shake evenly the ink bottle before pouring to prevent the ink sedimentation. Pour the ink into the corresponding ink cartridge.**

② **You can only hold the dampers on the sides because the middle of the dampers is very fragile.**

③ **When the dampers are installed and removed, it is best to put dust-free cloth or tissue on the both side of the print head to prevent ink from leakage, which will damage the print head and boards.**

④ **Turn the damper upside down and use a syringe holds against damper firmly to suck the ink out ; the ink in the damper should reach the position of the red line , and then put it back to the original position.**

⑤ **The damper should be installed in place to prevent ink leakage**

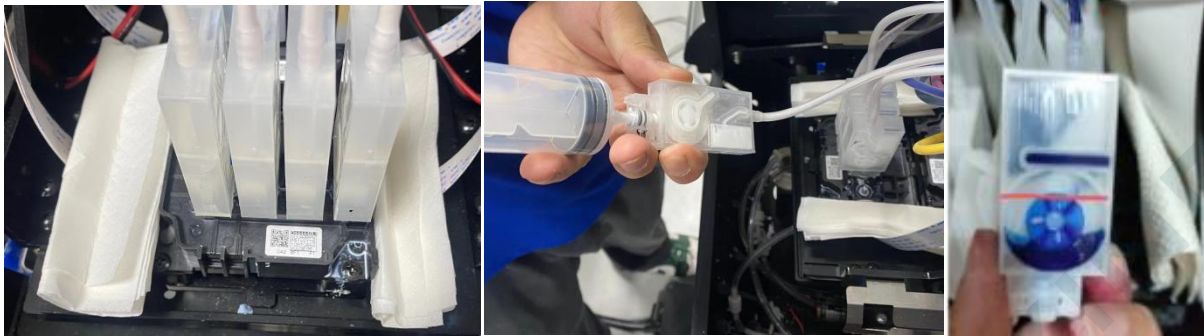

9. Power-on inspection

There is a wire with yellow and green color on the right corner of the printer, which should be connected the earth wire well. Besides the power supply cord, it is necessary to plug in the earth wire as well. If your printer does not connect to the earth wire, the boards and print heads will be damaged, If this is the reason for the damage to the boards and print heads, the printer's boards and print heads will not be covered under warranty.

10. Debug Before Printing

10.1 Confirm ink stack and cleaning parameters

Open the software → Advanced Mode → Manufacturer mode → Enter password 111111 → Ink stack capping should be aligned well with the print head; Confirm the pumping height (moisturizing height is consistent with pumping height), The ink stack should be lowered 1mm where it fits into the print head; Confirm the position of the flash spray height, ink stack

and print head place well; Confirm that the wiper is 0.2mm higher than the print head; Turn off the printer, then you manually push the carriage in a slow speed, observe whether the print head scratch on the film press clip, next adjust the height of the carriage, 0.2mm higher than the printing platform, observe whether the cables are pulled, need to sort out the cables.

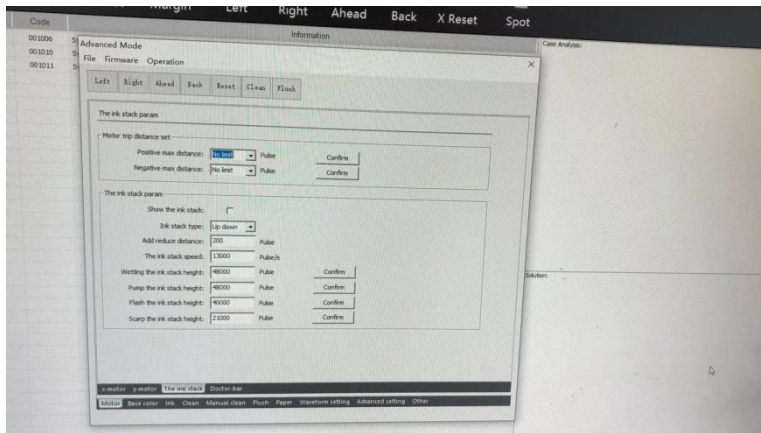

10.2 Print Nozzle Test & Confirm the status of Print Head

1. Print Nozzle Test

Connect the machine to the power supply and enter the printing software interface. (Note: the ink stack should be closed to the print head after the machine self-check is completed).

Load ink for 12 seconds and confirm that ink is flowing out of the waste ink tube, then stay still for 1-2 minutes, and then click the clean icon **“WEAK CLEAN”**. After the cleaning is complete, confirm that the platform is free of obstacles, then print a nozzle test. Then you observe the ink out of the print head, if there is no ink or ink missing on the test strip, **“WEAK CLEAN”** again. **If there is no improvement after cleaning for 2-3 times, Needs to contact our technicians.**

If the ink performance is not good, the print head should be cleaned well, and then print again (Once printing, you need to make a nozzle test firstly as mentioned above)

IF DON'T KNOW HOW TO CLEAN, please contact our technicians.

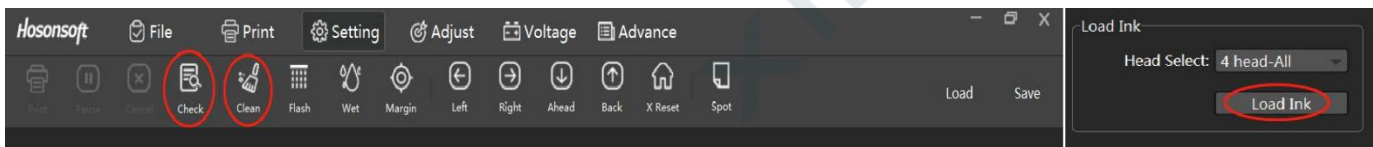

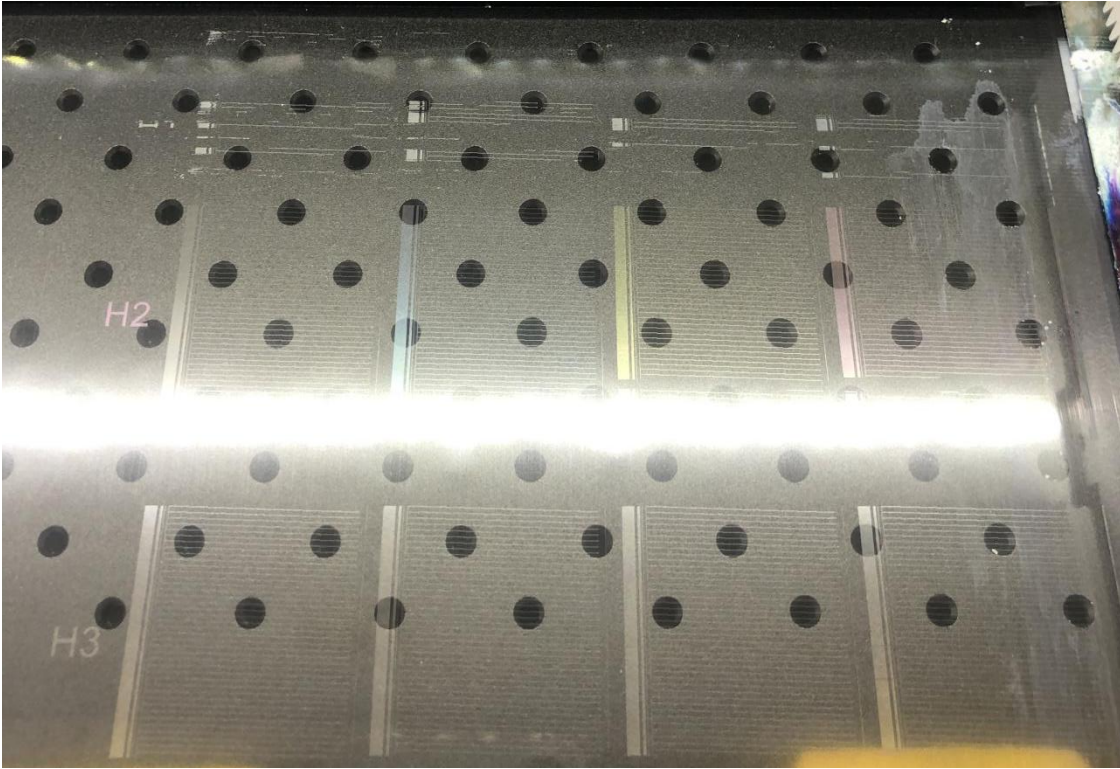

Test Strip with problem (ink not come out 100%, and all color not show in single line)

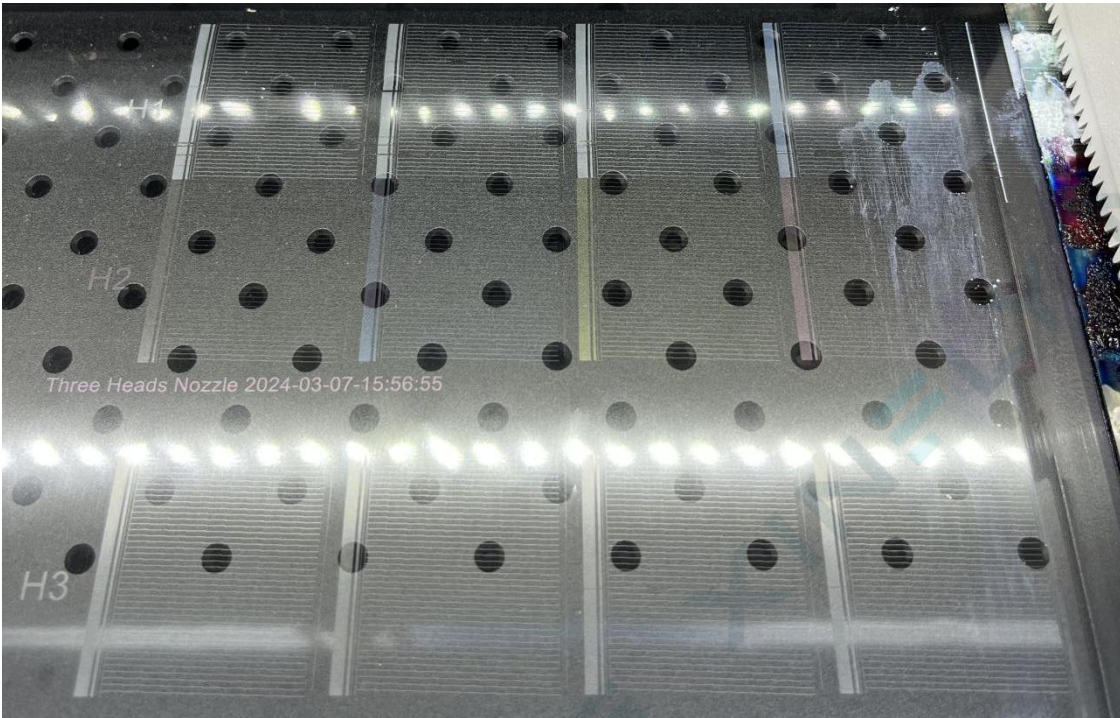

Normal Test Strip (all ink come out 100% and all color show in single line)

11. Alignment & Calibration

11.1 Vertical Alignment Of the Print Head

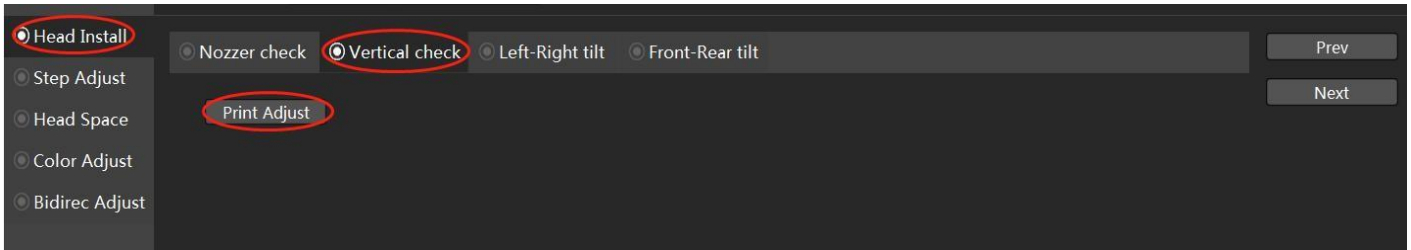

For vertical calibration, the vertical direction of the test chart required to be printed is a straight line. The vertical calibration chart below shows that the print head has been tilted and needs to be calibrated.

If there is a deviation, loosen the fixing screw of the print head and adjust the position of the print head. You can "push the print head up to the left". Then Print Adjust again, reach to form a line.

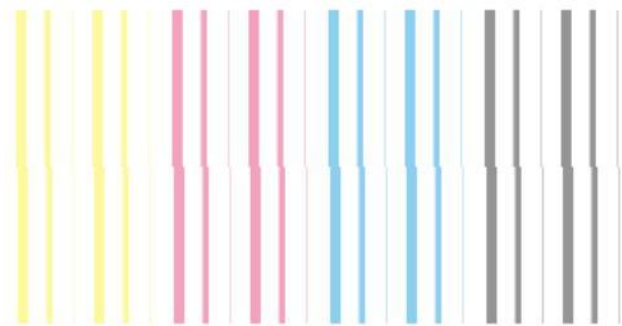

Enter the software option " Adjust" interface and align the print head vertically "Print Adjust".

11.2 Step calibration

Step calibration, Print Adjust.

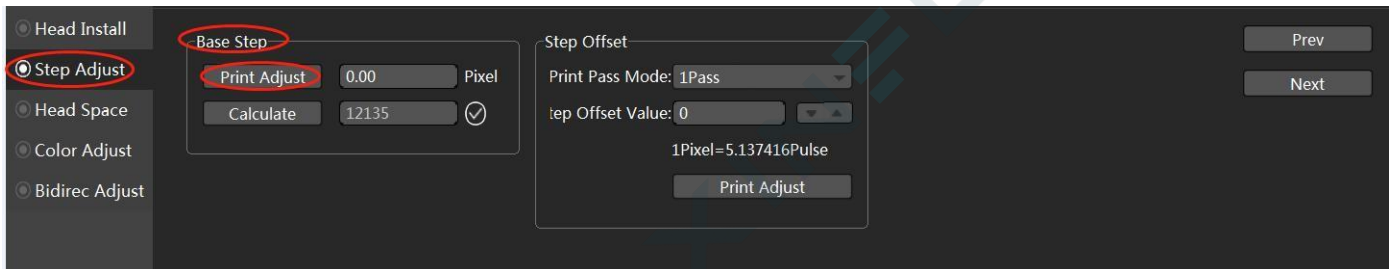

The calibration chart is at the value -2, and the lines completely overlap

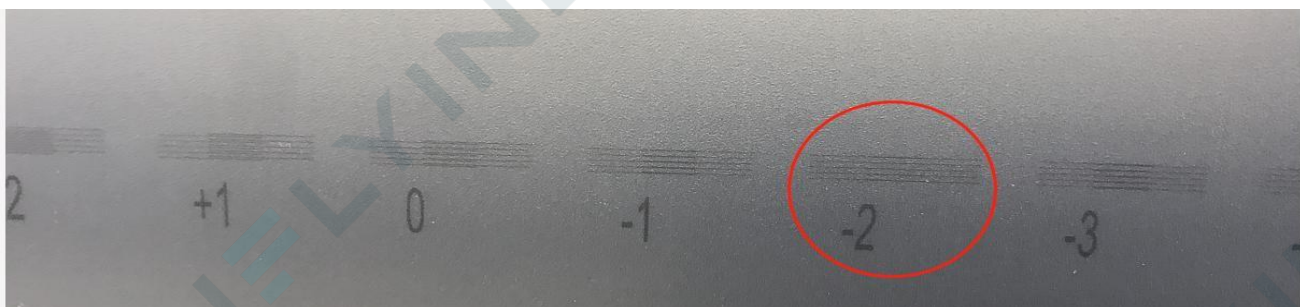

So enter the value -2 in the corresponding input box, and then click Calculate.

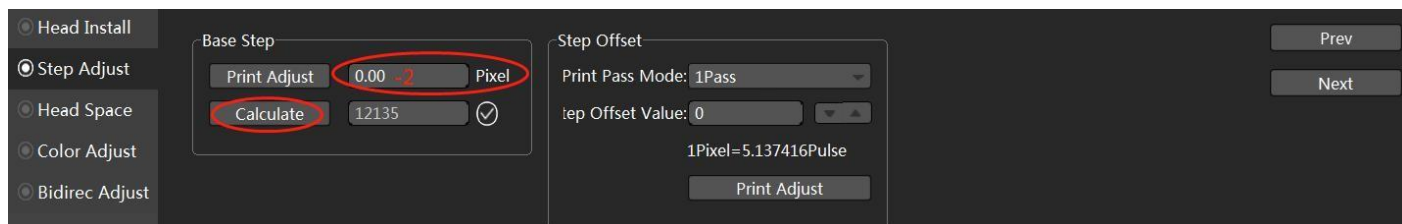

Print Adjust again and confirm that the line at the value 0 is the most uniform. Need to click the "Save" button in the upper right corner.

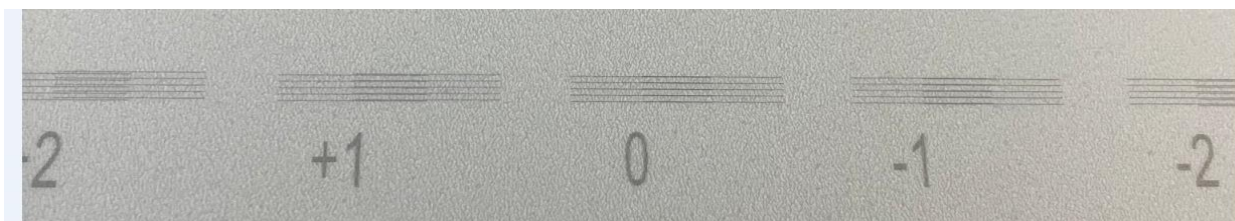

11.3 Calibration of nozzle horizontal space

Calibration of the horizontal distance between the print heads, Print Adjust.



The calibration chart is at the value +2, and the lines completely overlap.

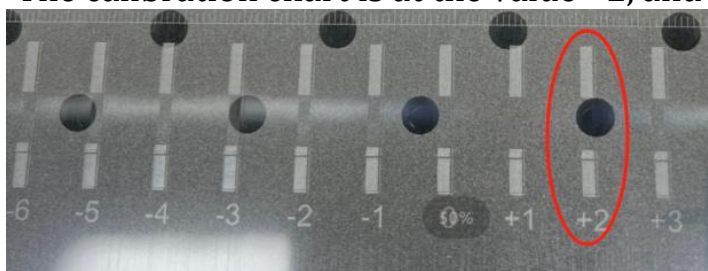

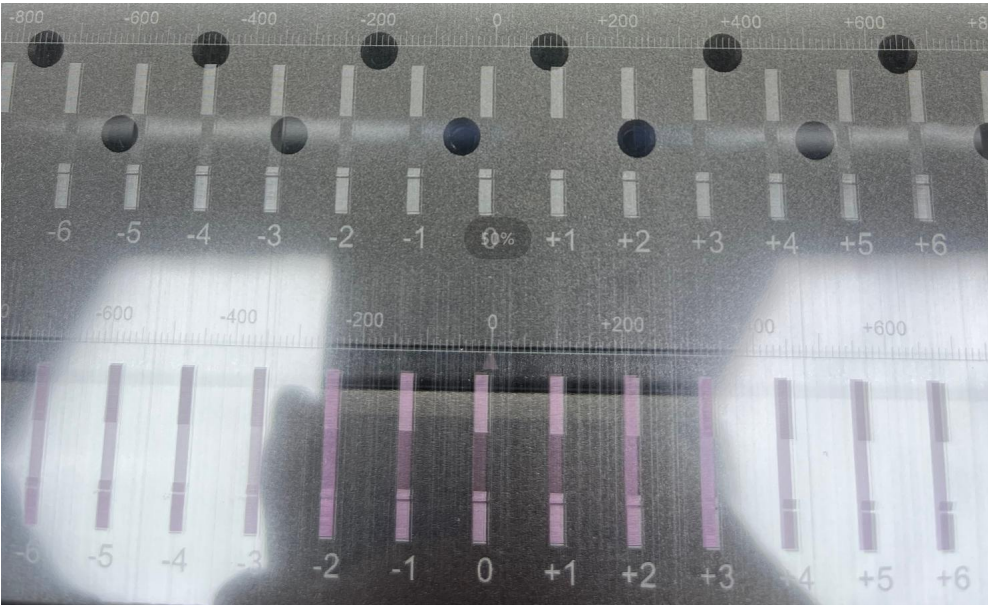

In the corresponding print head, increase or decrease the corresponding value in the input box of the corresponding printing direction.

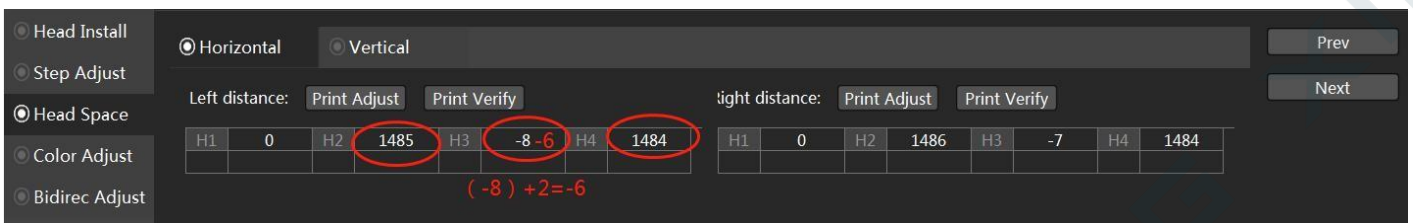

Print Adjust again and confirm that the line at the value 0 is the most uniform. Need to click the "Save" button in the upper right corner.

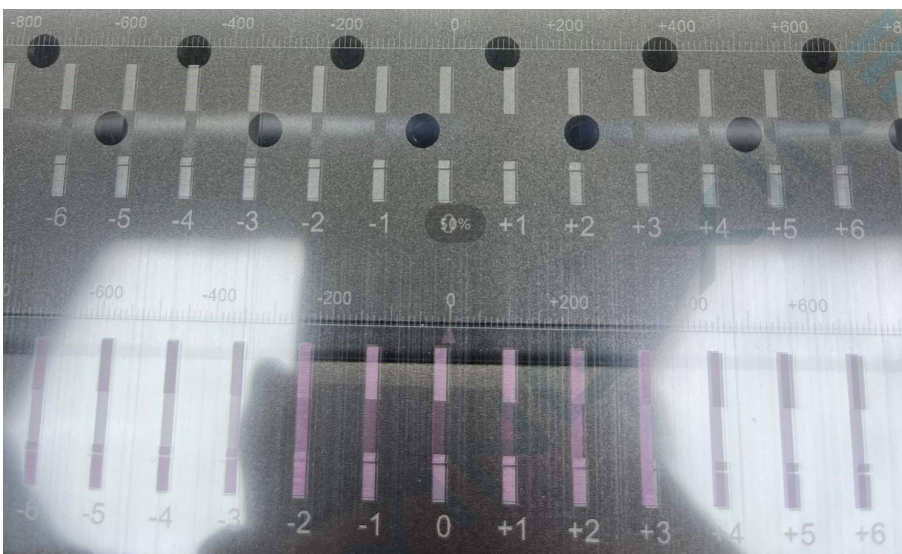

Then calibrate the direction to the right, the steps are the same as above.

11.4 Nozzle vertical space calibration

Calibration of vertical spacing between nozzles. Print Adjust.

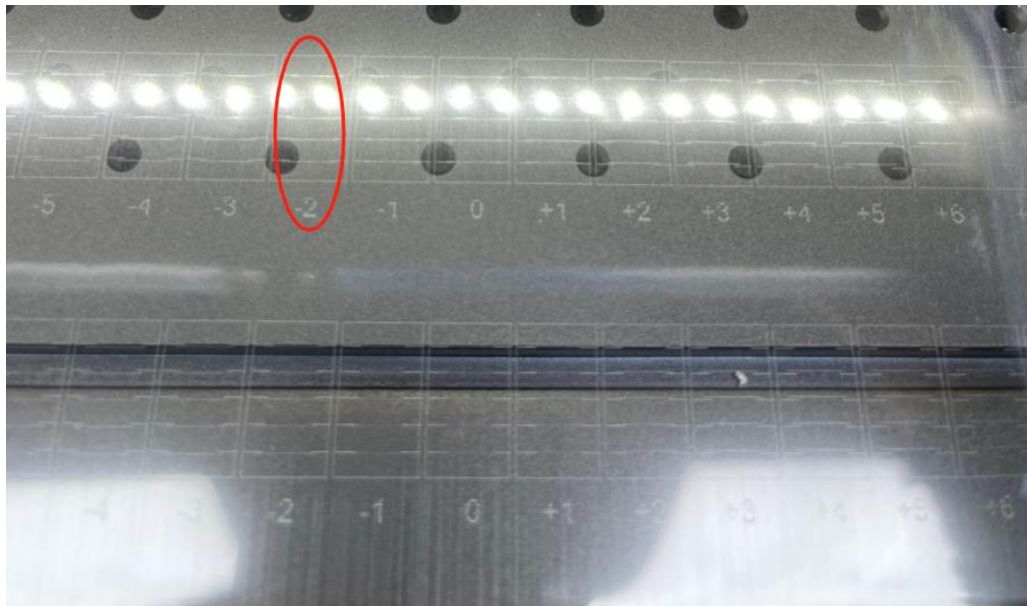
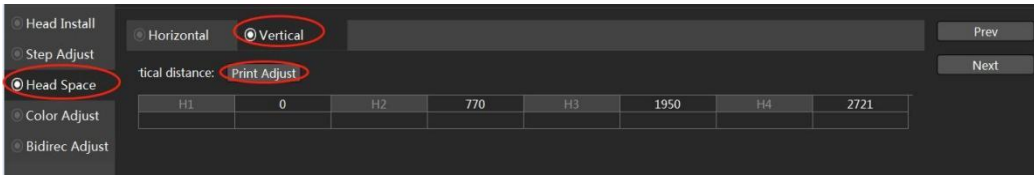

The calibration chart is at the value -2, and the lines completely overlap.

In the corresponding print head, increase or decrease the corresponding value in the input box of the corresponding printing direction.

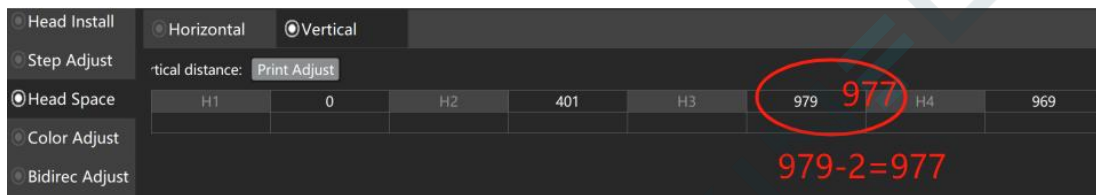

Print Adjust again and confirm that the line at the value 0 is the most uniform. Need to click the "Save" button in the upper right corner.

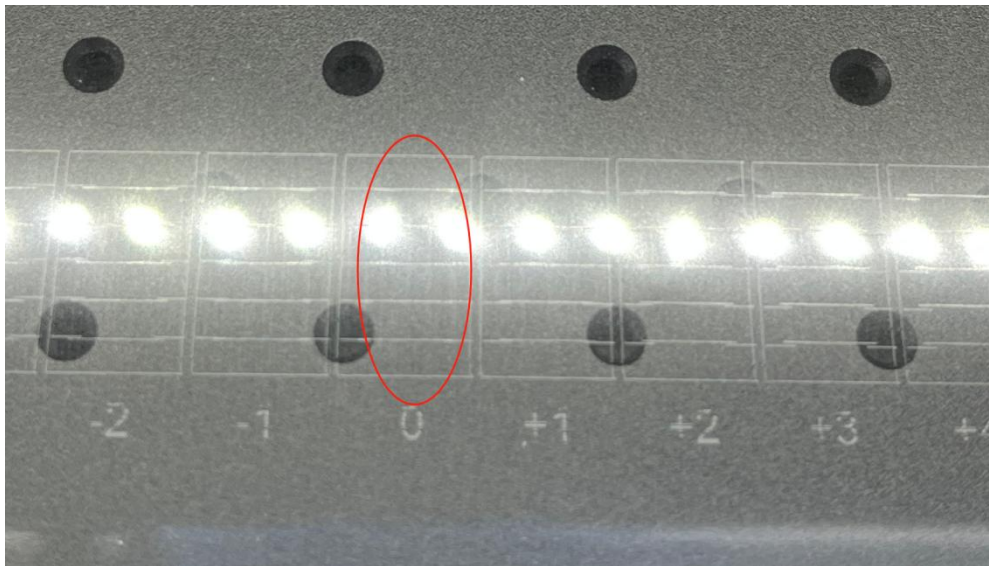

11.5 Bidirectional printing calibration

Finally, perform bidirectional printing calibration, Print Adjust.

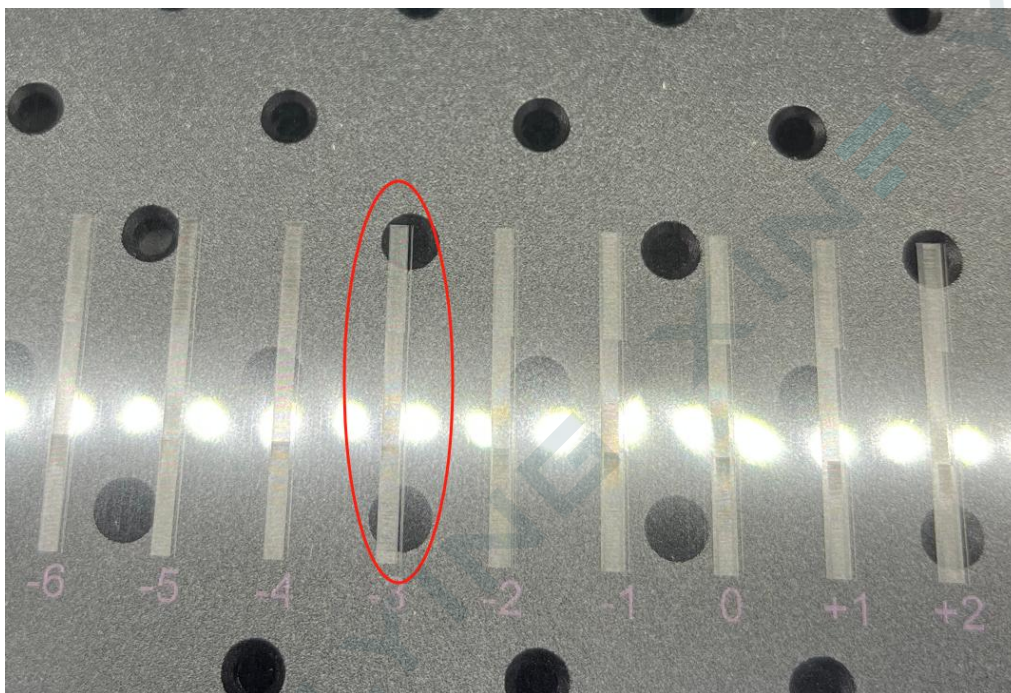
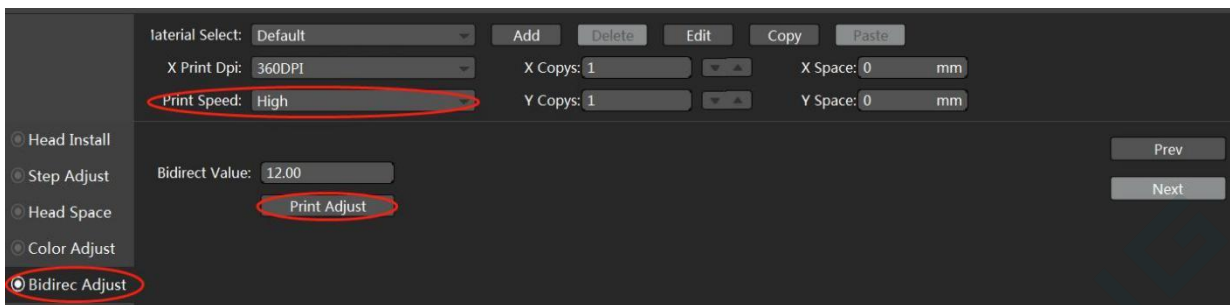

The calibration chart is at the value -3, and the lines completely overlap.

Select the corresponding printing speed, and increase or decrease the corresponding value according to the calibration chart.

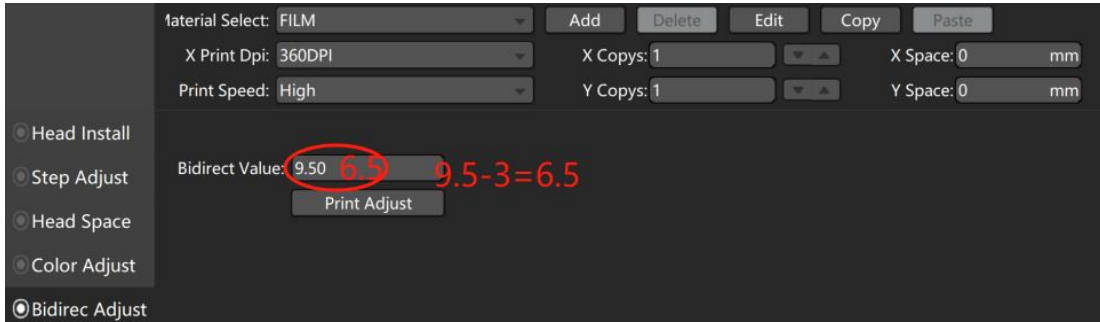

Print Adjust again and confirm that the line at the value 0 is the most uniform. Need to click the "Save" button in the upper right corner.

Finally, switch to different speeds to calibrate the two-way printing values and save them separately.

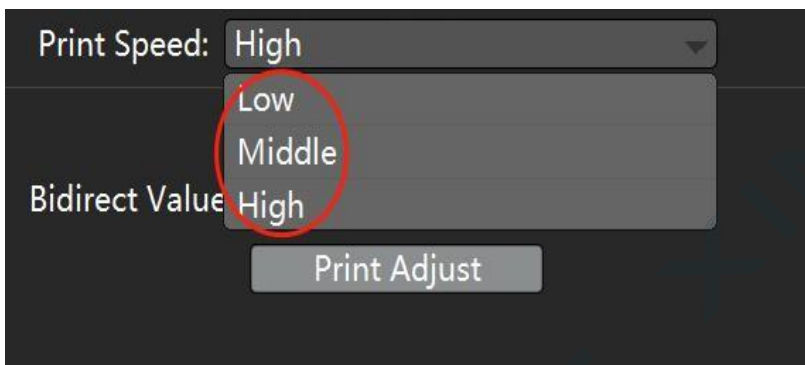
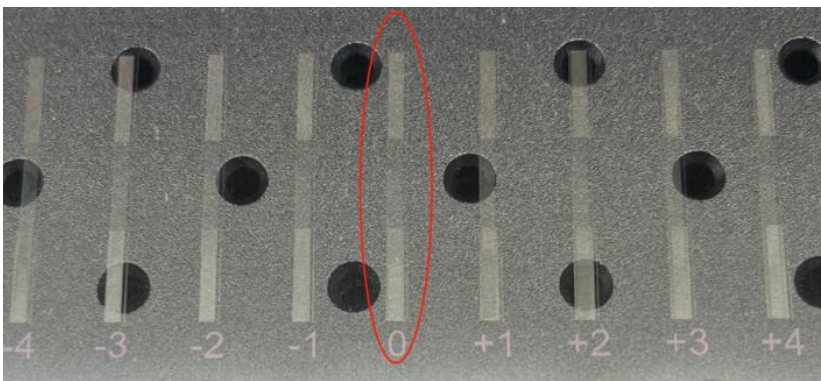

Background factory settings

Password:

Generally model:111111

Factory model: Ctrl+F12 into factory model,then enter password:222222

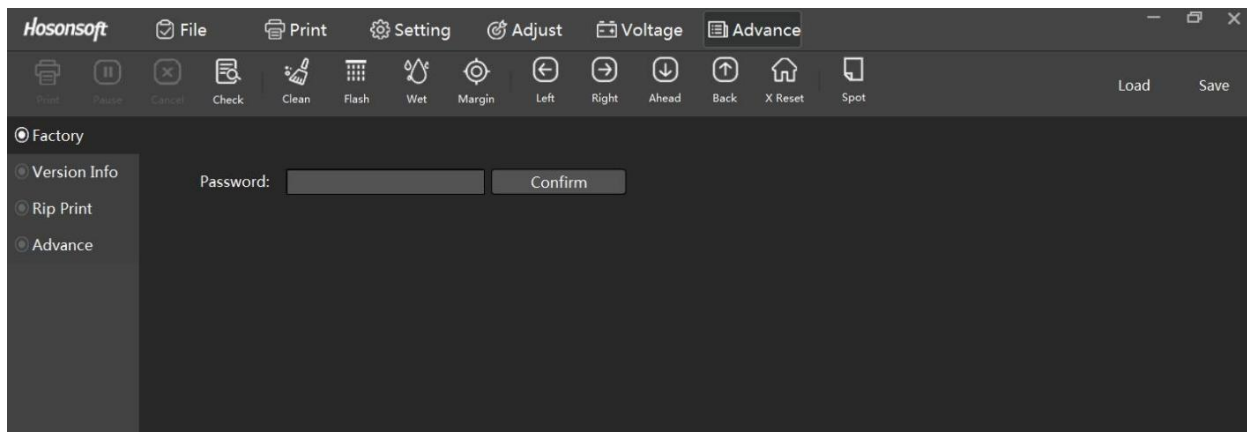

Version information

Click the version information in the advanced interface and enter the following interface:

Change key panel language

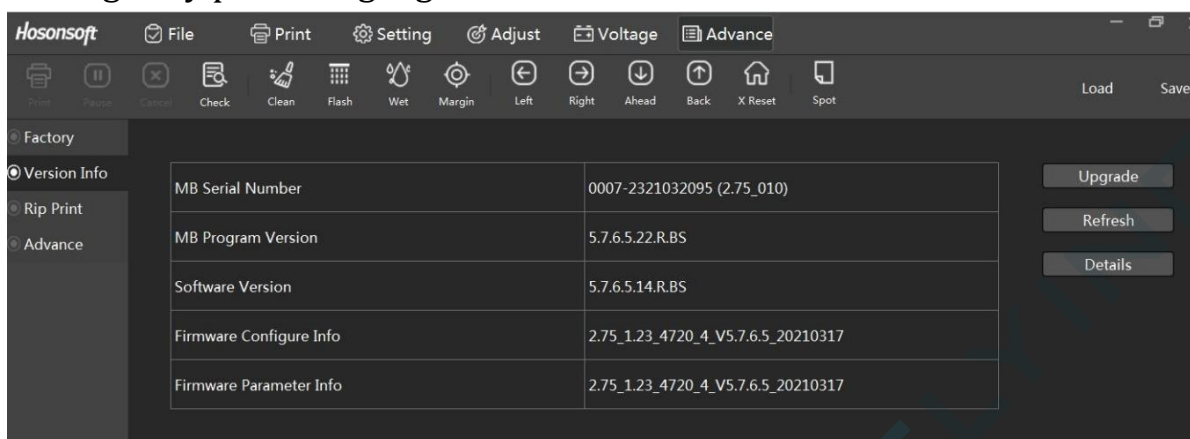

Select advance-encryption-language.as shown below

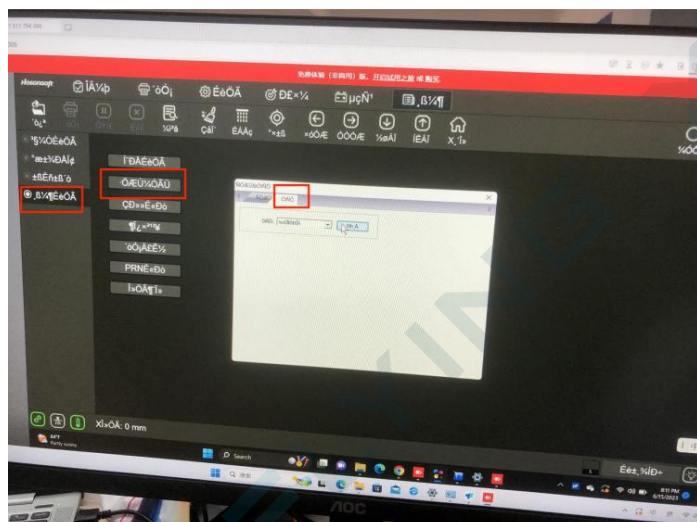

12. Precautions & Maintenance

Precautions for printing equipment

In order to ensure the good operation and extend the lifespan of the printer, it is essential to ensure that the printer is operated in an environment that strictly conforms to the standards. The following requirements are needed for the machine environment:

- (1) The printing room's temperature must be between 20°C - 35°C (68°F - 95°F), humidity ranges from 35% to 70%RH
- (2) The machine must be equipped with a voltage regulator or UPS (voltage fluctuation range should not exceed $\pm 5V$), which should be connected to the earth wire.

Maintenance of The Printer(According to our maintenance manual)

- (1) Check the status of the print head when starting up and shutting down the machine.
- (2) Close the software before shutting down and check whether the carriage is reset well.
- (3) Follow the maintenance manual we sent to perform daily maintenance on the printer.
- (4) Do not touch the heated printer platform.

Regarding holiday maintenance for the printer:

I believe that friends who use printers will be concerned about how to maintain the machine during holidays and ensure that the equipment can function properly after the holidays.

1. If there is someone at the printing room, you can just print the nozzle test everyday, which is perfect for the printer's maintenance, and there is no need to do the follow steps.
2. If there is no one at the printing room. You need to do follow these steps:
 - (1) First, print a test strip and check the nozzle status. If the test strip is in good condition, use UV-specific moisturizing solution to soak the print head.
 - (2) Reset well. The print head must be aligned with the ink pad and closed to seal and moisturize the print head. Otherwise, the print head may become clogged.
 - (3) Clamp the ink tube with the ink tube clip.
 - (4) Tighten all ink cartridge caps.
 - (5) Wash the waste ink tank.
 - (6) Seal print film to prevent moisture.
 - (7) DO NOT let your printer and shaker with dust, please take good measures to prevent dust from the machine.

Reminder:

If the machine encounters any malfunctions, please contact a technician for assistance with repairs. Incorrect operation may cause significant damage to the printer.